



47 Captive Screws

Styled knob series · M3 thread size

- Smooth knob meets UL-1950
- Designed for hand operation
- Spring ejected
- Wide variety of sizes, recesses and installation options

Material and Finish

Ferrule:

Press-in: Hardened carbon steel, zinc plated, chromate, plus sealer

Flare-in and Floating:

Aluminum, natural

P.C. board style: 300 Series stainless steel, passivated

Knob:

Aluminum, natural or black powder coated

Screw: Hardened carbon steel, zinc plated, chromate, plus sealer

Installation Notes

See pages 546-547, 627

Notes



To ensure you receive **SOUTHCO®** quality parts, look for the segmented circle

Recess Styles

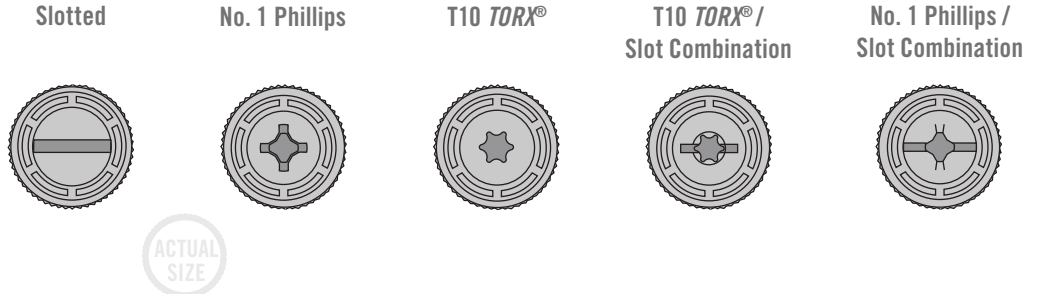

Knob Height and Screw Projection

(Flare-in style shown)

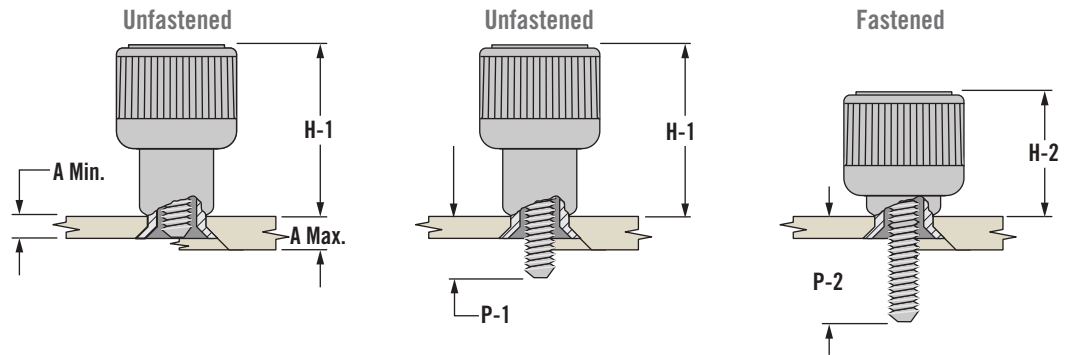

Installation Styles

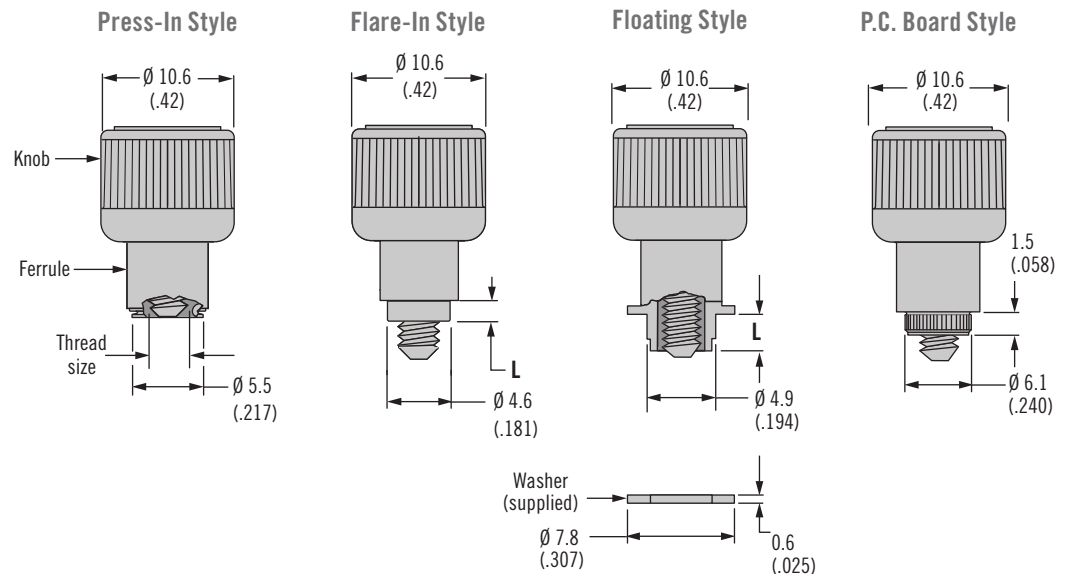

TORX® is a registered trademark of CAMCAR Innovations

Dimensions in millimeters (inch) unless otherwise stated

Installation Style	Knob Height		Outer Panel Dimensions		B	Total Float	Flange Length L	Screw Projection Beyond Outer Surface of Panel		Part Number				
	H-1	H-2	A Min.	A Max.				P-1	P-2	Slotted Recess	Phillips Recess	TORX® Recess	TORX® / Slot Combination	Phillips / Slot Combination
Press-In Style	11.3 (.45)	8.3 (.33)	0.9 (.036)	~	~	0.7 (.03)	~	0.8 (.03)	3.8 (.15)	47-90-101-24	47-90-121-24	47-90-141-24	47-90-161-20	47-90-181-24
								2.5 (.10)	5.5 (.22)	47-91-101-24	47-91-121-24	47-91-141-24	47-91-161-20	47-91-181-24
								4 (.16)	7 (.28)	47-92-101-24	47-92-121-24	47-92-141-24	47-92-161-20	47-92-181-24
								5.6 (.22)	8.6 (.34)	47-93-101-24	47-93-121-24	47-93-141-24	47-93-161-20	47-93-181-24
P.C. Board Style	11.5 (.45)	8.3 (.33)	1.6 (.061)	~	~	0.7 (.03)	~	1.5 (.06)	4.5 (.18)	47-95-101-34	47-95-121-34	47-95-141-34	47-95-161-30	47-95-181-34
Flare-In Style	11.5 (.45)	8.1 (.32)	0.8 (.031)	1.5 (.058)	0.4 (.015)	0.7 (.03)	1.0 (.041)	0.8 (.03)	4 (.16)	47-80-101-14	47-80-121-14	47-80-141-14	47-80-161-10	47-80-181-14
			1.5 (.059)	2.5 (.098)	0.4 (.015)		1.8 (.070)	1.5 (.06)	4.7 (.19)	47-80-102-14	47-80-122-14	47-80-142-14	47-80-162-10	47-80-182-14
			2.5 (.098)	4 (.156)	0.8 (.031)		2.6 (.104)	2.5 (.10)	5.7 (.22)	47-80-103-14	47-80-123-14	47-80-143-14	47-80-163-10	47-80-183-14
			4 (.157)	5.6 (.219)	2.4 (.093)		4.2 (.166)	4 (.16)	7.2 (.28)	47-80-105-14	47-80-125-14	47-80-145-14	47-80-165-10	47-80-185-14
			5.6 (.220)	7.1 (.281)	4 (.156)		5.8 (.299)	5.6 (.22)	8.8 (.35)	47-80-107-14	47-80-127-14	47-80-147-14	47-80-167-10	47-80-187-14
			0.8 (.031)	1.5 (.058)	0.4 (.015)		1.0 (.041)	2.5 (.10)	5.7 (.22)	47-81-101-14	47-81-121-14	47-81-141-14	47-81-161-10	47-81-181-14
			4 (.16)	7.2 (.28)	47-82-101-14		47-82-121-14	47-82-141-14	47-82-161-10	47-82-181-14				
			5.6 (.22)	8.8 (.35)	47-83-101-14		47-83-121-14	47-83-141-14	47-83-161-10	47-83-181-14				
			3.2 (.13)	6.4 (.25)	47-81-102-14		47-81-122-14	47-81-142-14	47-81-162-10	47-81-182-14				
			4.7 (.19)	7.9 (.31)	47-82-102-14		47-82-122-14	47-82-142-14	47-82-162-10	47-82-182-14				
			6.3 (.25)	9.5 (.37)	47-83-102-14		47-83-122-14	47-83-142-14	47-83-162-10	47-83-182-14				
			Floating Style	11.4 (.45)	8.6 (.34)		~	0.8 (.031)	2 (.080)	2.0 (.08)	2.6 (.101)	1.9 (.07)	5.1 (.20)	47-80-110-14
3.4 (.13)	6.6 (.26)	47-81-110-14				47-81-130-14	47-81-150-14	47-81-170-10	47-81-190-14					
5 (.19)	8.2 (.32)	47-82-110-14				47-82-130-14	47-82-150-14	47-82-170-10	47-82-190-14					
1.9 (.07)	5.1 (.20)	47-80-111-14				47-80-131-14	47-80-151-14	47-80-171-10	47-80-191-14					
3.4 (.13)	6.6 (.26)	47-81-111-14				47-81-131-14	47-81-151-14	47-81-171-10	47-81-191-14					
5 (.19)	8.2 (.32)	47-82-111-14				47-82-131-14	47-82-151-14	47-82-171-10	47-82-191-14					
3.4 (.13)	6.6 (.26)	47-80-112-14				47-80-132-14	47-80-152-14	47-80-172-10	47-80-192-14					
5 (.19)	8.2 (.32)	47-81-112-14				47-81-132-14	47-81-152-14	47-81-172-10	47-81-192-14					

Part numbers in shaded rows (shown in table) are fully retracting in minimum panel thickness

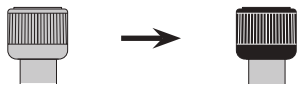

To add a black powder coated finish, change the part number from the table as shown:

- Change 1 to 5: 47-80-102-14
47-80-102-54
- Change 2 to 6: 47-80-102-24
47-80-102-64
- Change 3 to 7: 47-80-102-34
47-80-102-74



For a smooth knob, change the part number from the table as shown:

- Change 0 to 1: 47-90-161-20
47-90-161-21
- Change 4 to 5: 47-90-101-24
47-90-101-25

Part Number

See table

All screw part numbers shown in table are for a natural knob finish and a knurled knob

For black finish and smooth knob options, minimums may apply

TORX® is a registered trademark of CAMCAR Innovations



47 Captive Screws

Styled knob series · M3.5 thread size

- Smooth knob meets UL-1950
- Designed for hand operation
- Spring ejected
- Wide variety of sizes, recesses and installation options

Material and Finish

Ferrule:

Press-in: Hardened carbon steel, zinc plate, chromate, plus sealer
P.C. board: 300 Series stainless steel, passivated

Flare-in, floating and snap-in: Aluminum, natural

Knob: Aluminum, natural or black powder coated

Screw: Hardened carbon steel, zinc plated, chromate, plus sealer

Installation Notes

See pages 546-547, 627

Notes



To ensure you receive **SOUTHCO**® quality parts, look for the segmented circle

Recess Styles

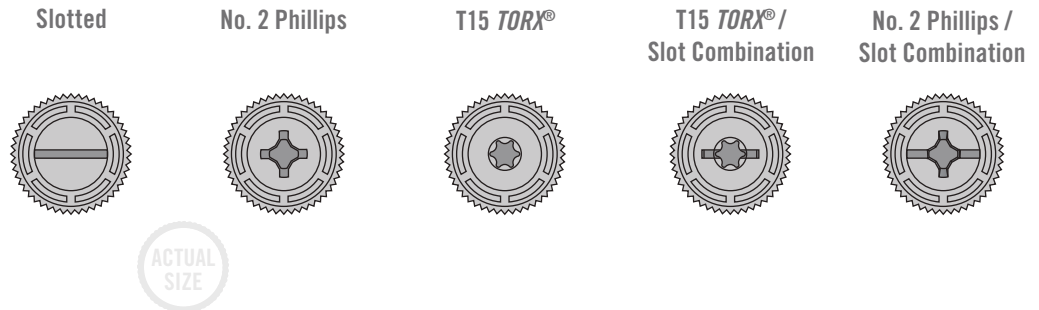

Knob Height and Screw Projection

(Flare-in style shown)

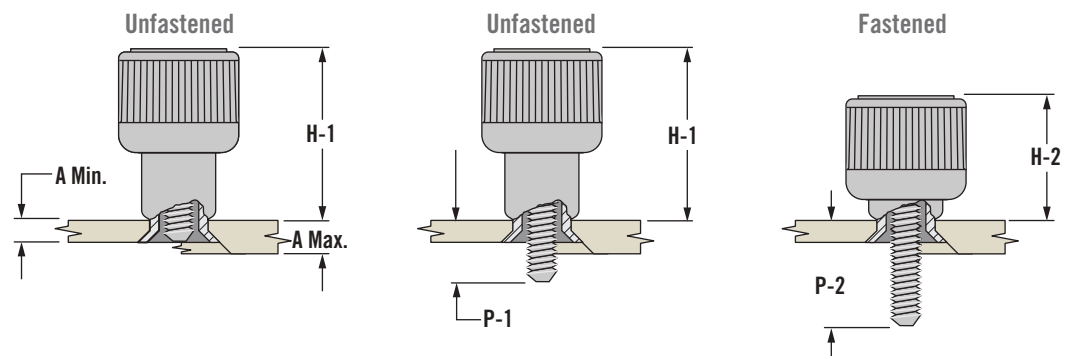

Installation Styles

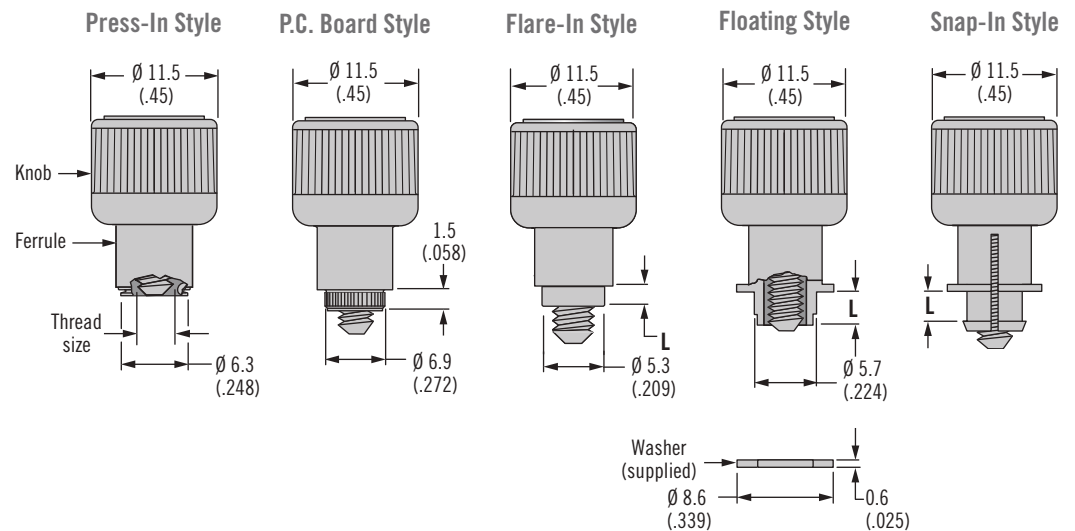

TORX® is a registered trademark of CAMCAR Innovations

Dimensions in millimeters (inch) unless otherwise stated

Installation Style	Knob Height		Outer Panel Dimensions		B	Total Float	Flange Length L	Screw Projection Beyond Outer Surface of Panel		Part Number				
	H-1	H-2	A Min.	A Max.				P-1	P-2	Slotted Recess	Phillips Recess	TORX® Recess	TORX® / Slot Combination	Phillips / Slot Combination
Press-In Style	15.9 (.63)	11.2 (.44)	0.9 (.036)	~	~	0.8 (.03)	~	0.5 (.02)	5.3 (.21)	47-90-201-24	47-90-221-24	47-90-241-24	47-90-261-20	47-90-281-24
								2.1 (.09)	6.9 (.27)	47-91-201-24	47-91-221-24	47-91-241-24	47-91-261-20	47-91-281-24
								3.7 (.15)	8.5 (.33)	47-92-201-24	47-92-221-24	47-92-241-24	47-92-261-20	47-92-281-24
								5.3 (.21)	10.1 (.40)	47-93-201-24	47-93-221-24	47-93-241-24	47-93-261-20	47-93-281-24
P.C. Board Style	14.8 (.58)	10 (.39)	1.6 (.061)	~	~	0.8 (.03)	~	1.4 (.06)	6.2 (.24)	47-95-201-34	47-95-221-34	47-95-241-34	47-95-261-30	47-95-281-34
Flare-In Style	15.3 (.60)	10.4 (.41)	1.5 (.058)	3.2 (.125)	0.4 (.015)	0.8 (.03)	1.8 (.07)	1.1 (.04)	6 (.24)	47-80-202-14	47-80-222-14	47-80-242-14	47-80-262-10	47-80-282-14
			3.2 (.126)	4.8 (.189)	1.6 (.062)		3.4 (.135)	2.7 (.11)	7.6 (.30)	47-80-204-14	47-80-224-14	47-80-244-14	47-80-264-10	47-80-284-14
			4.8 (.188)	6.4 (.250)	3.2 (.125)		5 (.197)	4.3 (.17)	9.2 (.36)	47-80-206-14	47-80-226-14	47-80-246-14	47-80-266-10	47-80-286-14
			6.4 (.252)	7.9 (.312)	4.8 (.189)		6.6 (.26)	5.9 (.23)	10.8 (.43)	47-80-208-14	47-80-228-14	47-80-248-14	47-80-268-10	47-80-288-14
			1.5 (.058)	3.2 (.125)	0.4 (.015)		1.8 (.07)	2.7 (.11)	7.6 (.30)	47-81-202-14	47-81-222-14	47-81-242-14	47-81-262-10	47-81-282-14
			3.2 (.126)	4.8 (.189)	1.6 (.062)		1.8 (.07)	4.3 (.17)	9.2 (.36)	47-82-202-14	47-82-222-14	47-82-242-14	47-82-262-10	47-82-282-14
			4.8 (.188)	6.4 (.250)	3.2 (.125)		1.8 (.07)	5.9 (.23)	10.8 (.43)	47-83-202-14	47-83-222-14	47-83-242-14	47-83-262-10	47-83-282-14
			6.4 (.252)	7.9 (.312)	4.8 (.189)		1.8 (.07)	4.3 (.17)	9.2 (.36)	47-81-204-14	47-81-224-14	47-81-244-14	47-81-264-10	47-81-284-14
			1.5 (.058)	3.2 (.125)	0.4 (.015)		3.4 (.135)	5.9 (.23)	10.8 (.43)	47-82-204-14	47-82-224-14	47-82-244-14	47-82-264-10	47-82-284-14
			3.2 (.126)	4.8 (.189)	1.6 (.062)		5 (.197)	5.9 (.23)	10.8 (.43)	47-81-206-14	47-81-226-14	47-81-246-14	47-81-266-10	47-81-286-14
Floating Style	15.4 (.60)	10.6 (.42)	~	0.8 (.031)	2.1 (.083)	2.2 (.09)	2.9 (.113)	2.4 (.09)	7.2 (.28)	47-80-210-14	47-80-230-14	47-80-250-14	47-80-270-10	47-80-290-14
			0.8 (.031)	1.6 (.063)	2.9 (.114)		2.9 (.113)	4 (.16)	8.8 (.35)	47-81-210-14	47-81-230-14	47-81-250-14	47-81-270-10	47-81-290-14
			1.6 (.063)	2.4 (.094)	3.7 (.146)		2.9 (.113)	5.6 (.22)	10.4 (.41)	47-82-210-14	47-82-230-14	47-82-250-14	47-82-270-10	47-82-290-14
			0.8 (.031)	1.6 (.063)	2.9 (.114)		3.7 (.144)	2.4 (.09)	7.2 (.28)	47-80-211-14	47-80-231-14	47-80-251-14	47-80-271-10	47-80-291-14
			1.6 (.063)	2.4 (.094)	3.7 (.146)		3.7 (.144)	4 (.16)	8.8 (.35)	47-81-211-14	47-81-231-14	47-81-251-14	47-81-271-10	47-81-291-14
			0.8 (.031)	1.6 (.063)	2.9 (.114)		3.7 (.144)	5.6 (.22)	10.4 (.41)	47-82-211-14	47-82-231-14	47-82-251-14	47-82-271-10	47-82-291-14
			1.6 (.063)	2.4 (.094)	3.7 (.146)		4.5 (.176)	4 (.16)	8.8 (.35)	47-80-212-14	47-80-232-14	47-80-252-14	47-80-272-10	47-80-292-14
			0.8 (.031)	1.6 (.063)	2.9 (.114)		4.5 (.176)	5.6 (.22)	10.4 (.41)	47-81-212-14	47-81-232-14	47-81-252-14	47-81-272-10	47-81-292-14
Snap-In Style	15.4 (.60)	10.6 (.42)	0.5 (.02)	1 (.039)	2 (.079)	0.8 (.03)	1.1 (.044)	0.8 (.03)	5.6 (.22)	47-90-210-14	47-90-230-14	47-90-250-14	47-90-270-10	47-90-290-14
			1 (.039)	1.6 (.063)	2.6 (.103)		1.1 (.044)	2.4 (.09)	7.2 (.28)	47-91-210-14	47-91-230-14	47-91-250-14	47-91-270-10	47-91-290-14
			0.5 (.02)	1 (.039)	2 (.079)		1.1 (.044)	4 (.16)	8.8 (.35)	47-92-210-14	47-92-230-14	47-92-250-14	47-92-270-10	47-92-290-14
			1 (.039)	1.6 (.063)	2.6 (.103)		1.1 (.044)	5.6 (.22)	10.4 (.41)	47-93-210-14	47-93-230-14	47-93-250-14	47-93-270-10	47-93-290-14
			0.5 (.02)	1 (.039)	2 (.079)		1.7 (.067)	2.4 (.09)	7.2 (.28)	47-90-212-14	47-90-232-14	47-90-252-14	47-90-272-10	47-90-292-14
			1 (.039)	1.6 (.063)	2.6 (.103)		1.7 (.067)	4 (.16)	8.8 (.35)	47-91-212-14	47-91-232-14	47-91-252-14	47-91-272-10	47-91-292-14
			0.5 (.02)	1 (.039)	2 (.079)		1.7 (.067)	5.6 (.22)	10.4 (.41)	47-92-212-14	47-92-232-14	47-92-252-14	47-92-272-10	47-92-292-14
			1 (.039)	1.6 (.063)	2.6 (.103)		1.7 (.067)	5.6 (.22)	10.4 (.41)	47-92-212-14	47-92-232-14	47-92-252-14	47-92-272-10	47-92-292-14
			0.5 (.02)	1 (.039)	2 (.079)		1.7 (.067)	5.6 (.22)	10.4 (.41)	47-92-212-14	47-92-232-14	47-92-252-14	47-92-272-10	47-92-292-14
			1 (.039)	1.6 (.063)	2.6 (.103)		1.7 (.067)	5.6 (.22)	10.4 (.41)	47-92-212-14	47-92-232-14	47-92-252-14	47-92-272-10	47-92-292-14

Part numbers in shaded rows (shown in table) are fully retracting in minimum panel thickness



To add a black powder coated finish, change the part number from the table as shown:

- Change 1 to 5: 47-80-102-14
- 47-80-102-54
- Change 2 to 6: 47-80-102-24
- 47-80-102-64
- Change 3 to 7: 47-80-102-34
- 47-80-102-74



For a smooth knob, change the part number from the table as shown:

- Change 0 to 1: 47-90-161-20
- 47-90-161-21
- Change 4 to 5: 47-90-101-24
- 47-90-101-25

Part Number

See table

All screw part numbers shown in table are for a natural knob finish and a knurled knob

For black finish and smooth knob options, minimums may apply

TORX® is a registered trademark of CAMCAR Innovations



47 Captive Screws

Styled knob series · M4 thread size

- Designed for hand operation
- Spring ejected
- Wide variety of sizes, recesses and installation options

Material and Finish

Ferrule:

Press-in: Hardened carbon steel, zinc plate, chromate, plus sealer

Flare-in, floating and snap-in: Aluminum, natural

Knob: Aluminum, natural or black powder coated

Screw: Hardened carbon steel, zinc plated, chromate, plus sealer

Installation Notes

See pages 546-547, 627

Notes



To ensure you receive **SOUTHCO**® quality parts, look for the segmented circle

Recess Styles



Knob Height and Screw Projection

(Flare-in style shown)

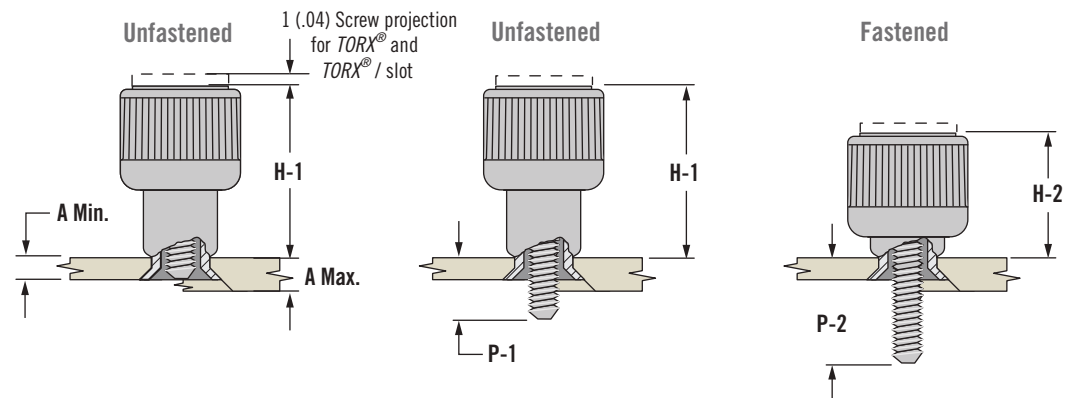

Installation Styles

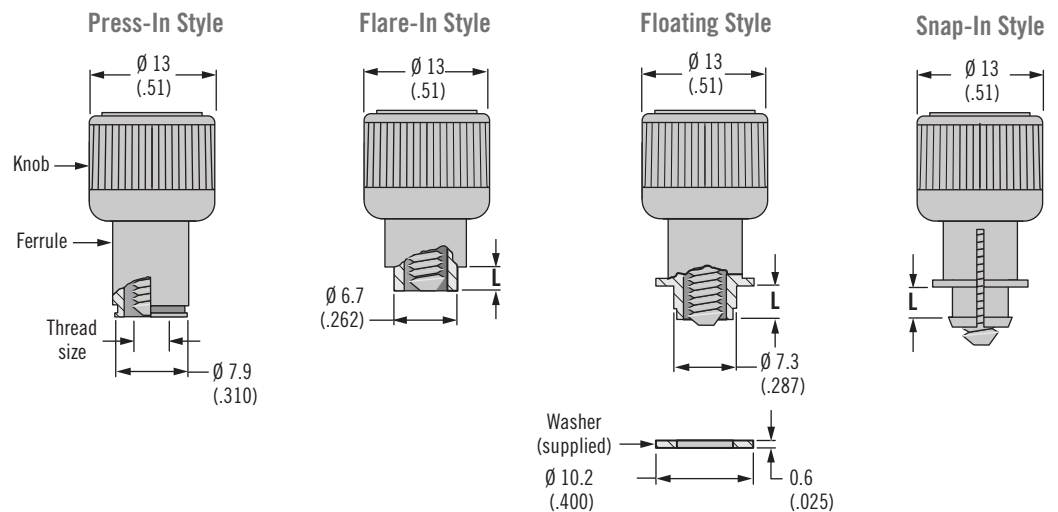

TORX® is a registered trademark of CAMCAR Innovations

Dimensions in millimeters (inch) unless otherwise stated

Installation Style	Knob Height		Outer Panel Dimensions		B	Total Float	Flange Length L	Screw Projection Beyond Outer Surface of Panel		Part Number				
	H-1	H-2	A Min.	A Max.				P-1	P-2	Slotted Recess	Phillips Recess	TORX® Recess	TORX® / Slot Combination	Phillips / Slot Combination
Press-In Style	16.2 (.64)	11.3 (.45)	0.9 (.036)	~	~	0.8 (.03)	~	0.6 (.02)	5.6 (.22)	47-90-301-24	47-90-321-24	47-90-341-20	47-90-361-20	47-90-381-20
								2.2 (.09)	7.2 (.28)	47-91-301-24	47-91-321-24	47-91-341-20	47-91-361-20	47-91-381-20
								3.8 (.15)	8.7 (.34)	47-92-301-24	47-92-321-24	47-92-341-20	47-92-361-20	47-92-381-20
								5.4 (.21)	10.3 (.41)	47-93-301-24	47-93-321-24	47-93-341-20	47-93-361-20	47-93-381-20
Flare-In Style	15.6 (.61)	10.5 (.41)	1.5 (.058)	3.2 (.125)	0.4 (.015)	0.9 (.03)	1.8 (.070)	1.2 (.05)	6.3 (.25)	47-80-302-14	47-80-322-14	47-80-342-10	47-80-362-10	47-80-382-10
			3.2 (.126)	4.8 (.189)	1.6 (.062)		3.4 (.135)	2.8 (.11)	7.9 (.31)	47-80-304-14	47-80-324-14	47-80-344-10	47-80-364-10	47-80-384-10
			4.8 (.189)	6.4 (.251)	3.2 (.125)		5 (.197)	4.4 (.17)	9.5 (.37)	47-80-306-14	47-80-326-14	47-80-346-10	47-80-366-10	47-80-386-10
			6.4 (.251)	7.9 (.312)	4.8 (.187)		6.6 (.26)	6 (.24)	11.1 (.44)	47-80-308-14	47-80-328-14	47-80-348-10	47-80-368-10	47-80-388-10
			1.5 (.058)	3.2 (.125)	0.4 (.015)		1.8 (.07)	2.8 (.11)	7.9 (.31)	47-81-302-14	47-81-322-14	47-81-342-10	47-81-362-10	47-81-382-10
			3.2 (.126)	4.8 (.189)	1.6 (.062)		3.4 (.135)	4.4 (.17)	9.5 (.37)	47-82-302-14	47-82-322-14	47-82-342-10	47-82-362-10	47-82-382-10
			4.8 (.189)	6.4 (.250)	3.2 (.125)		6 (.24)	11.1 (.44)	47-83-302-14	47-83-322-14	47-83-342-10	47-83-362-10	47-83-382-10	
			3.2 (.126)	4.8 (.189)	1.6 (.062)		4.4 (.17)	9.5 (.37)	47-81-304-14	47-81-324-14	47-81-344-10	47-81-364-10	47-81-384-10	
			4.8 (.189)	6.4 (.250)	3.2 (.125)		6 (.24)	11.1 (.44)	47-82-304-14	47-82-324-14	47-82-344-10	47-82-364-10	47-82-384-10	
			1.5 (.058)	3.2 (.125)	0.4 (.015)		5 (.197)	6 (.24)	11.1 (.44)	47-81-306-14	47-81-326-14	47-81-346-10	47-81-366-10	47-81-386-10
			3.2 (.126)	4.8 (.189)	1.6 (.062)		3.2 (.127)	2.4 (.09)	7.2 (.28)	47-80-310-14	47-80-330-14	47-80-350-10	47-80-370-10	47-80-390-10
			Floating Style	16.2 (.64)	11.2 (.44)		~	0.8 (.031)	2.3 (.09)	2.3 (.09)	4 (.16)	8.8 (.35)	47-81-310-14	47-81-330-14
0.8 (.031)	1.6 (.063)	3.1 (.121)				5.6 (.22)	10.4 (.41)	47-82-310-14	47-82-330-14		47-82-350-10	47-82-370-10	47-82-390-10	
1.6 (.063)	2.4 (.094)	3.9 (.153)				2.4 (.09)	7.2 (.28)	47-80-311-14	47-80-331-14		47-80-351-10	47-80-371-10	47-80-391-10	
4 (.16)	8.8 (.35)	47-81-311-14				47-81-331-14	47-81-351-10	47-81-371-10	47-81-391-10					
5.6 (.22)	10.4 (.41)	47-82-311-14				47-82-331-14	47-82-351-10	47-82-371-10	47-82-391-10					
4 (.16)	7.2 (.28)	47-80-312-14				47-80-332-14	47-80-352-10	47-80-372-10	47-80-392-10					
5.6 (.22)	8.8 (.35)	47-81-312-14				47-81-332-14	47-81-352-10	47-81-372-10	47-81-392-10					
1.1 (.044)	2.7 (.11)	7.2 (.28)				47-91-310-14	47-91-330-14	47-91-350-10	47-91-370-10		47-91-390-10			
Snap-In Style	15.7 (.62)	11.2 (.44)	0.5 (.02)	1 (.039)	2 (.079)	0.9 (.03)	1.1 (.044)	2.7 (.11)	7.2 (.28)	47-91-310-14	47-91-330-14	47-91-350-10	47-91-370-10	47-91-390-10
			1 (.039)	1.6 (.063)	2.6 (.102)		4.3 (.17)	8.8 (.35)	47-92-310-14	47-92-330-14	47-92-350-10	47-92-370-10	47-92-390-10	
			1.6 (.063)	2.5 (.098)	3.5 (.138)		5.8 (.23)	10.4 (.41)	47-93-310-14	47-93-330-14	47-93-350-10	47-93-370-10	47-93-390-10	
			1.1 (.044)	2.7 (.11)	7.2 (.28)		1.7 (.068)	2.7 (.11)	7.2 (.28)	47-90-312-14	47-90-332-14	47-90-352-10	47-90-372-10	47-90-392-10
			4.3 (.17)	8.8 (.35)	47-91-312-14		47-91-332-14	47-91-352-10	47-91-372-10	47-91-392-10				
			5.9 (.23)	10.4 (.41)	47-92-312-14		47-92-332-14	47-92-352-10	47-92-372-10	47-92-392-10				
			2.7 (.11)	7.2 (.28)	47-90-314-14		47-90-334-14	47-90-354-10	47-90-374-10	47-90-394-10				
			4.3 (.17)	8.8 (.35)	47-91-314-14		47-91-334-14	47-91-354-10	47-91-374-10	47-91-394-10				
			5.9 (.23)	10.4 (.41)	47-92-314-14		47-92-334-14	47-92-354-10	47-92-374-10	47-92-394-10				

Part numbers in shaded rows (shown in table) are fully retracting in minimum panel thickness



To add a black powder coated finish, change the part number from the table as shown:

- Change 1 to 5: 47-80-102-14
- 47-80-102-54
- Change 2 to 6: 47-80-102-24
- 47-80-102-64



For a smooth knob, change the part number from the table as shown:

- Change 0 to 1: 47-90-161-20
- 47-90-161-21
- Change 4 to 5: 47-90-101-24
- 47-90-101-25

Part Number

See table

All screw part numbers shown in table are for a natural knob finish and a knurled knob

For black finish and smooth knob options, minimums may apply



47 Captive Screws

Styled knob series · M5 thread size

- Designed for hand operation
- Spring ejected
- Wide variety of sizes, recesses and installation options

Material and Finish

Ferrule:

Press-in: Hardened carbon steel, zinc plate, chromate, plus sealer

Flare-in, floating and snap-in: Aluminum, natural

Knob: Aluminum, natural or black powder coated

Screw: Hardened carbon steel, zinc plated, chromate, plus sealer

Installation Notes

See pages 546-547, 627

Notes



To ensure you receive **SOUTHCO®** quality parts, look for the segmented circle

Recess Styles

Slotted

No. 2 Phillips

T25 TORX®

T25 TORX® /
Slot Combination

No. 2 Phillips /
Slot Combination

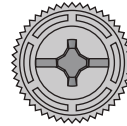
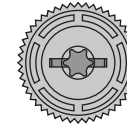
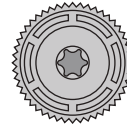
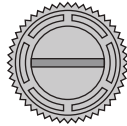

Knob Height and Screw Projection

(Flare-in style shown)

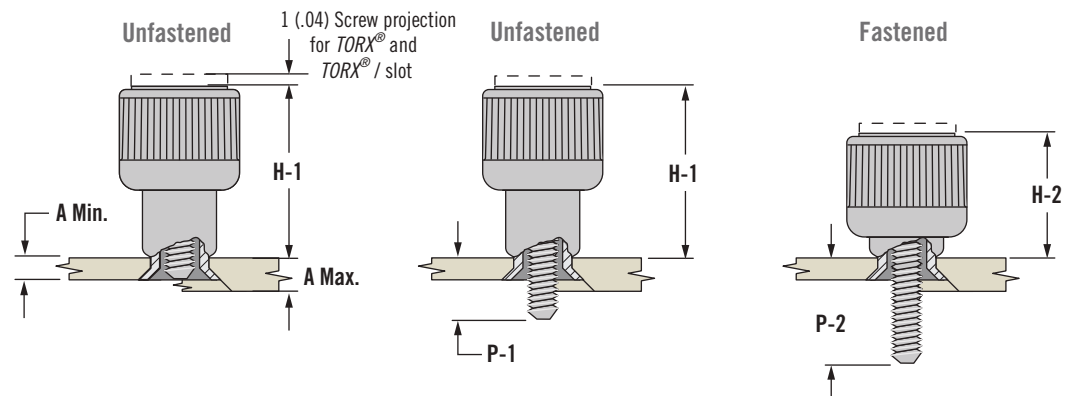

Installation Styles

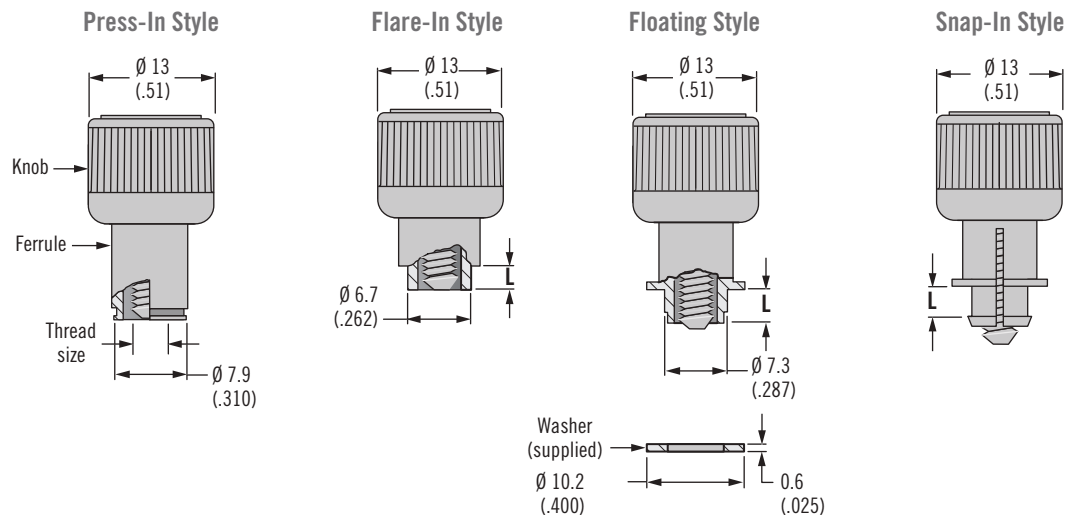

TORX® is a registered trademark of CAMCAR Innovations

Dimensions in millimeters (inch) unless otherwise stated

Installation Style	Knob Height		Outer Panel Dimensions			Total Float	Flange Length L	Screw Projection Beyond Outer Surface of Panel		Part Number					
	H-1	H-2	A Min.	A Max.	B			P-1	P-2	Slotted Recess	Phillips Recess	TORX® Recess	TORX® / Slot Combination	Phillips / Slot Combination	
Press-In Style	16.2 (.64)	11.3 (.45)	0.9 (.036)	~	~	0.6 (.02)	~	0.6 (.024)	5.5 (.22)	47-90-501-24	47-90-521-24	47-90-541-20	47-90-561-20	47-90-581-20	
								2.2 (.087)	7.1 (.28)	47-91-501-24	47-91-521-24	47-91-541-20	47-91-561-20	47-91-581-20	
								3.8 (.15)	8.7 (.34)	47-92-501-24	47-92-521-24	47-92-541-20	47-92-561-20	47-92-581-20	
								5.4 (.21)	10.3 (.41)	47-93-501-24	47-93-521-24	47-93-541-20	47-93-561-20	47-93-581-20	
Flare-In Style	15.6 (.61)	10.5 (.41)	1.5 (.058)	3.2 (.125)	0.4 (.015)	0.6 (.02)	1.8 (.070)	1.2 (.05)	6.3 (.25)	47-80-502-14	47-80-522-14	47-80-542-10	47-80-562-10	47-80-582-10	
			3.2 (.126)	4.8 (.189)	1.6 (.062)		3.4 (.135)	2.8 (.11)	7.9 (.31)	47-80-504-14	47-80-524-14	47-80-544-10	47-80-564-10	47-80-584-10	
			4.8 (.189)	6.4 (.250)	3.2 (.125)		5 (.197)	4.4 (.17)	9.5 (.37)	47-80-506-14	47-80-526-14	47-80-546-10	47-80-566-10	47-80-586-10	
			6.3 (.251)	7.9 (.312)	4.8 (.189)		6.6 (.260)	6 (.24)	11.1 (.44)	47-80-508-14	47-80-528-14	47-80-548-10	47-80-568-10	47-80-588-10	
			1.5 (.058)	3.2 (.125)	0.4 (.015)		1.8 (.070)	2.8 (.11)	7.9 (.31)	47-81-502-14	47-81-522-14	47-81-542-10	47-81-562-10	47-81-582-10	
			3.2 (.126)	4.8 (.189)	1.6 (.062)		3.4 (.135)	4.4 (.17)	9.5 (.37)	47-82-502-14	47-82-522-14	47-82-542-10	47-82-562-10	47-82-582-10	
			4.8 (.189)	6.4 (.250)	3.2 (.125)		5 (.197)	4.4 (.17)	9.5 (.37)	47-83-502-14	47-83-522-14	47-83-542-10	47-83-562-10	47-83-582-10	
			6.3 (.251)	7.9 (.312)	4.8 (.189)		6.6 (.260)	6 (.24)	11.1 (.44)	47-83-504-14	47-81-524-14	47-81-544-10	47-81-564-10	47-81-584-10	
			1.5 (.058)	3.2 (.125)	0.4 (.015)		1.8 (.070)	4.4 (.17)	9.5 (.37)	47-81-504-14	47-81-524-14	47-81-544-10	47-81-564-10	47-81-584-10	
			3.2 (.126)	4.8 (.189)	1.6 (.062)		3.4 (.135)	6 (.24)	11.1 (.44)	47-82-504-14	47-82-524-14	47-82-544-10	47-82-564-10	47-82-584-10	
			4.8 (.189)	6.4 (.250)	3.2 (.125)		5 (.197)	6 (.24)	11.1 (.44)	47-81-506-14	47-81-526-14	47-81-546-10	47-81-566-10	47-81-586-10	
			Floating Style	16 (.63)	11.2 (.44)		~	0.8 (.031)	2.3 (.090)	2.3 (.09)	3.2 (.127)	2.4 (.09)	7.2 (.28)	47-80-510-14	47-80-530-14
0.8 (.031)	1.6 (.063)	3.1 (.121)				4 (.158)	4 (.16)	8.8 (.35)	47-81-510-14		47-81-530-14	47-81-550-10	47-81-570-10	47-81-590-10	
1.6 (.063)	2.4 (.094)	3.9 (.153)				4 (.158)	5.6 (.22)	10.4 (.41)	47-82-510-14		47-82-530-14	47-82-550-10	47-82-570-10	47-82-590-10	
~	0.8 (.031)	2.3 (.090)				4 (.158)	2.4 (.09)	7.2 (.28)	47-80-511-14		47-80-531-14	47-80-551-10	47-80-571-10	47-80-591-10	
0.8 (.031)	1.6 (.063)	3.1 (.121)				4 (.158)	4 (.16)	8.8 (.35)	47-81-511-14		47-81-531-14	47-81-551-10	47-81-571-10	47-81-591-10	
1.6 (.063)	2.4 (.094)	3.9 (.153)				4 (.158)	5.6 (.22)	10.4 (.41)	47-82-511-14		47-82-531-14	47-82-551-10	47-82-571-10	47-82-591-10	
~	0.8 (.031)	2.3 (.090)				4.8 (.190)	4 (.16)	8.8 (.35)	47-80-512-14		47-80-532-14	47-80-552-10	47-80-572-10	47-80-592-10	
0.8 (.031)	1.6 (.063)	3.1 (.121)				4.8 (.190)	5.6 (.22)	10.4 (.41)	47-81-512-14		47-81-532-14	47-81-552-10	47-81-572-10	47-81-592-10	
1.6 (.063)	2.4 (.094)	3.9 (.153)				4.8 (.190)	4 (.16)	8.8 (.35)	47-80-510-14		47-90-530-14	47-90-550-10	47-90-570-10	47-90-590-10	
0.5 (.020)	1 (.039)	2 (.079)				1.1 (.044)	1.1 (.04)	5.6 (.22)	47-90-510-14		47-91-530-14	47-91-550-10	47-91-570-10	47-91-590-10	
0.5 (.020)	1 (.039)	2 (.079)				1.1 (.044)	1.1 (.044)	2.7 (.11)	7.2 (.28)		47-91-510-14	47-91-530-14	47-91-550-10	47-91-570-10	47-91-590-10
0.5 (.020)	1 (.039)	2 (.079)				1.1 (.044)	1.1 (.044)	4.3 (.17)	8.8 (.35)		47-92-510-14	47-92-530-14	47-92-550-10	47-92-570-10	47-92-590-10
0.5 (.020)	1 (.039)	2 (.079)	1.1 (.044)	1.1 (.044)	5.9 (.23)	10.4 (.41)	47-93-510-14	47-93-530-14	47-93-550-10	47-93-570-10	47-93-590-10				
1 (.039)	1.6 (.063)	2.6 (.103)	1.7 (.068)	1.7 (.068)	2.7 (.11)	7.2 (.28)	47-90-512-14	47-90-532-14	47-90-552-10	47-90-572-10	47-90-592-10				
1 (.039)	1.6 (.063)	2.6 (.103)	1.7 (.068)	1.7 (.068)	4.3 (.17)	8.8 (.35)	47-91-512-14	47-91-532-14	47-91-552-10	47-91-572-10	47-91-592-10				
1 (.039)	1.6 (.063)	2.6 (.103)	1.7 (.068)	1.7 (.068)	5.9 (.23)	10.4 (.41)	47-92-512-14	47-92-532-14	47-92-552-10	47-92-572-10	47-92-592-10				
1.6 (.063)	2.5 (.098)	3.5 (.138)	2.6 (.103)	2.6 (.103)	2.7 (.11)	7.2 (.28)	47-90-514-14	47-90-534-14	47-90-554-10	47-90-574-10	47-90-594-10				
1.6 (.063)	2.5 (.098)	3.5 (.138)	2.6 (.103)	2.6 (.103)	4.3 (.17)	8.8 (.35)	47-91-514-14	47-91-534-14	47-91-554-10	47-91-574-10	47-91-594-10				
1.6 (.063)	2.5 (.098)	3.5 (.138)	2.6 (.103)	2.6 (.103)	5.9 (.23)	10.4 (.41)	47-92-514-14	47-92-534-14	47-92-554-10	47-92-574-10	47-92-594-10				

Part numbers in shaded rows (shown in table) are fully retracting in minimum panel thickness



To add a black powder coated finish, change the part number from the table as shown:

- Change 1 to 5: 47-80-102-14
- 47-80-102-54
- Change 2 to 6: 47-80-102-24
- 47-80-102-64



For a smooth knob, change the part number from the table as shown:

- Change 0 to 1: 47-90-161-20
- 47-90-161-21
- Change 4 to 5: 47-90-101-24
- 47-90-101-25

Part Number

See table

All screw part numbers shown in table are for a natural knob finish and a knurled knob

For black finish and smooth knob options, minimums may apply



47 Captive Screws

Styled knob series · M6 thread size

- Designed for hand operation
- Spring ejected
- Wide variety of sizes, recesses and installation options

Material and Finish

Ferrule:

Press-in: Hardened carbon steel, zinc plate, chromate, plus sealer

Flare-in and Floating:

Aluminum, natural

Knob: Aluminum, natural or black powder coated

Screw: Hardened carbon steel, zinc plated, chromate, plus sealer

Installation Notes

See pages 546-547, 627

Notes

 To ensure you receive **SOUTHCO®** quality parts, look for the segmented circle

Recess Styles



Knob Height and Screw Projection

(Flare-in style shown)

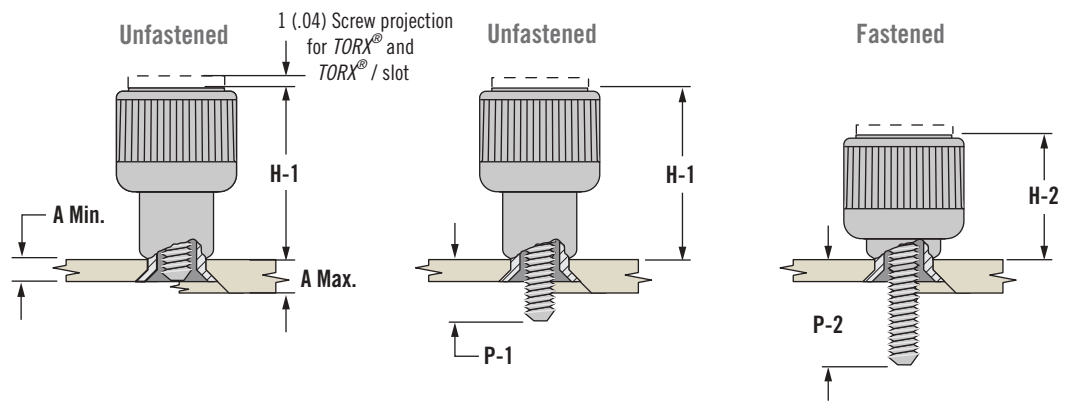

Installation Styles

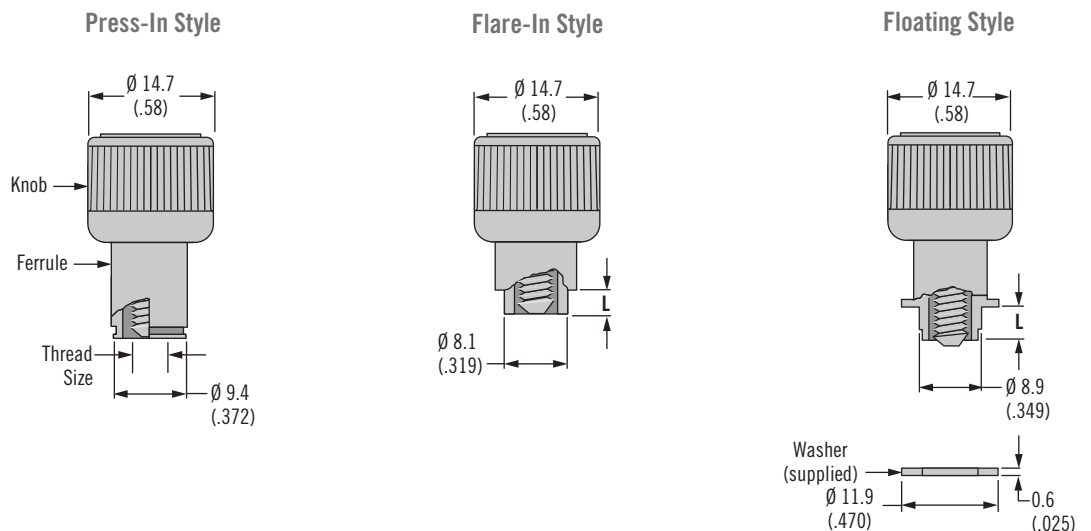

TORX® is a registered trademark of CAMCAR Innovations

Dimensions in millimeters (inch) unless otherwise stated

Installation Style	Knob Height		Outer Panel Dimensions		B	Total Float	Flange Length L	Screw Projection Beyond Outer Surface of Panel		Part Number								
	H-1	H-2	A Min.	A Max.				P-1	P-2	Slotted Recess	Phillips Recess	TORX® Recess	TORX® / Slot Combination	Phillips / Slot Combination				
Press-In Style	20 (.79)	13.4 (.53)	0.9 (.036)	~	~	0.8 (.03)	~	0.5 (.02)	7.1 (.28)	47-90-601-24	47-90-621-24	47-90-641-20	47-90-661-20	47-90-681-20				
								2.1 (.08)	8.7 (.34)	47-91-601-24	47-91-621-24	47-91-641-20	47-91-661-20	47-91-681-20				
								3.7 (.15)	10.3 (.41)	47-92-601-24	47-92-621-24	47-92-641-20	47-92-661-20	47-92-681-20				
								5.3 (.21)	11.9 (.47)	47-93-601-24	47-93-621-24	47-93-641-20	47-93-661-20	47-93-681-20				
Flare-In Style	19.3 (.76)	12.7 (.50)	1.5 (.058)	3.2 (.125)	0.4 (.015)	0.9 (.03)	1.8 (.070)	1.2 (.05)	7.8 (.31)	47-80-602-14	47-80-622-14	47-80-642-10	47-80-662-10	47-80-682-10				
			3.2 (.126)	4.8 (.189)	1.6 (.062)		3.4 (.135)	2.8 (.11)	9.4 (.31)	47-80-604-14	47-80-624-14	47-80-644-10	47-80-664-10	47-80-684-10				
			4.8 (.189)	6.4 (.250)	3.2 (.125)		5 (.197)	4.4 (.17)	11 (.43)	47-80-606-14	47-80-626-14	47-80-646-10	47-80-666-10	47-80-686-10				
			6.4 (.251)	7.9 (.312)	4.8 (.189)		6.6 (.260)	6 (.24)	12.6 (.50)	47-80-608-14	47-80-628-14	47-80-648-10	47-80-668-10	47-80-688-10				
			1.5 (.058)	3.2 (.125)	0.4 (.015)		1.8 (.070)	2.8 (.11)	9.4 (.37)	47-81-602-14	47-81-622-14	47-81-642-10	47-81-662-10	47-81-682-10				
			4.4 (.17)	11 (.43)	47-82-602-14			47-82-622-14	47-82-642-10	47-82-662-10	47-82-682-10							
			3.2 (.126)	4.8 (.189)	1.6 (.062)		3.4 (.135)	6 (.24)	12.6 (.50)	47-83-602-14	47-83-622-14	47-83-642-10	47-83-662-10	47-83-682-10				
			4.4 (.17)	11 (.43)	47-81-604-14			47-81-624-14	47-81-644-10	47-81-664-10	47-81-684-10							
			4.8 (.189)	6.4 (.250)	3.2 (.125)		5 (.197)	6 (.24)	12.6 (.50)	47-82-604-14	47-82-624-14	47-82-644-10	47-82-664-10	47-82-684-10				
			6 (.24)	12.6 (.50)	47-81-606-14			47-81-626-14	47-81-646-10	47-81-666-10	47-81-686-10							
			Floating Style	20 (.79)	13.3 (.52)		~	0.8 (.031)	2.5 (.097)	2.3 (.09)	3.2 (.127)	2.1 (.08)	8.8 (.35)	47-80-610-14	47-80-630-14	47-80-650-10	47-80-670-10	47-80-690-10
												3.7 (.15)	10.4 (.41)	47-81-610-14	47-81-630-14	47-81-650-10	47-81-670-10	47-81-690-10
												5.3 (.21)	12 (.47)	47-82-610-14	47-82-630-14	47-82-650-10	47-82-670-10	47-82-690-10
							0.8 (.031)	1.6 (.063)	3.3 (.128)		4 (.158)	2.1 (.08)	8.8 (.35)	47-80-611-14	47-80-631-14	47-80-651-10	47-80-671-10	47-80-691-10
3.7 (.15)	10.4 (.41)	47-81-611-14				47-81-631-14						47-81-651-10	47-81-671-10	47-81-691-10				
5.3 (.21)	12 (.47)	47-82-611-14				47-82-631-14						47-82-651-10	47-82-671-10	47-82-691-10				
1.6 (.063)	2.4 (.094)	4.1 (.160)				4.8 (.189)	3.7 (.15)	10.4 (.41)	47-80-612-14		47-80-632-14	47-80-652-10	47-80-672-10	47-80-692-10				
							5.3 (.21)	12 (.47)	47-81-612-14		47-81-632-14	47-81-652-10	47-81-672-10	47-81-692-10				

Part numbers in shaded rows (shown in table) are fully retracting in minimum panel thickness



To add a black powder coated finish, change the part number from the table as shown:

- Change 1 to 5: 47-80-102-14
- 47-80-102-54
- Change 2 to 6: 47-80-102-24
- 47-80-102-64



For a smooth knob, change the part number from the table as shown:

- Change 0 to 1: 47-90-161-20
- 47-90-161-21
- Change 4 to 5: 47-90-101-24
- 47-90-101-25

Part Number

See table

All screw part numbers shown in table are for a natural knob finish and a knurled knob

For black finish and smooth knob options, minimums may apply



47 Captive Screws

Styled knob series · 4-40 thread size

- Smooth knob meets UL-1950
- Designed for hand operation
- Spring ejected
- Wide variety of sizes, recesses and installation options

Material and Finish

Ferrule:

Press-in: Hardened carbon steel, zinc plate, chromate, plus sealer
P.C. board style:

300 Series stainless steel

Flare-in and Floating:

Aluminum, natural

Knob: Aluminum, natural or black powder coated

Screw: Hardened carbon steel, zinc plated, chromate, plus sealer

Installation Notes

See pages 546-547, 627

Notes



To ensure you receive **SOUTHCO®** quality parts, look for the segmented circle

Recess Styles

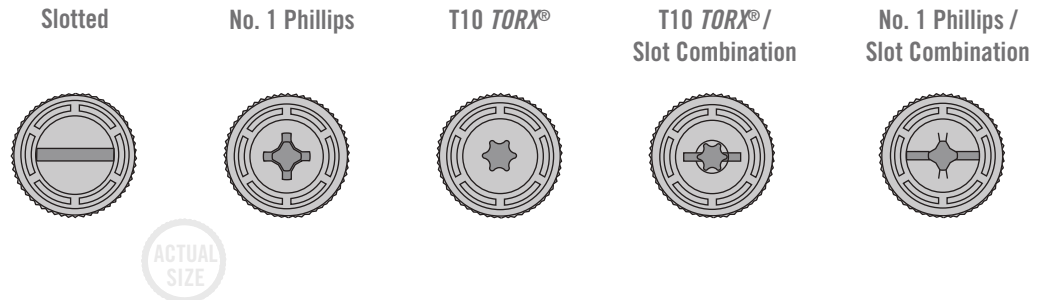

Knob Height and Screw Projection

(Flare-in style shown)

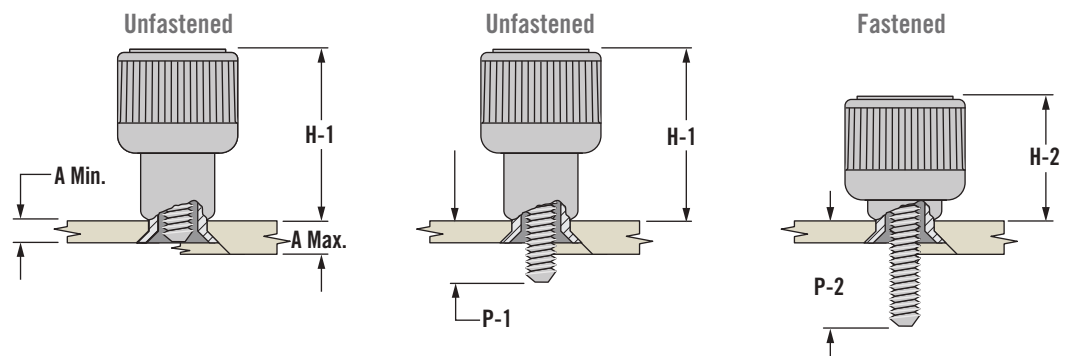

Installation Styles

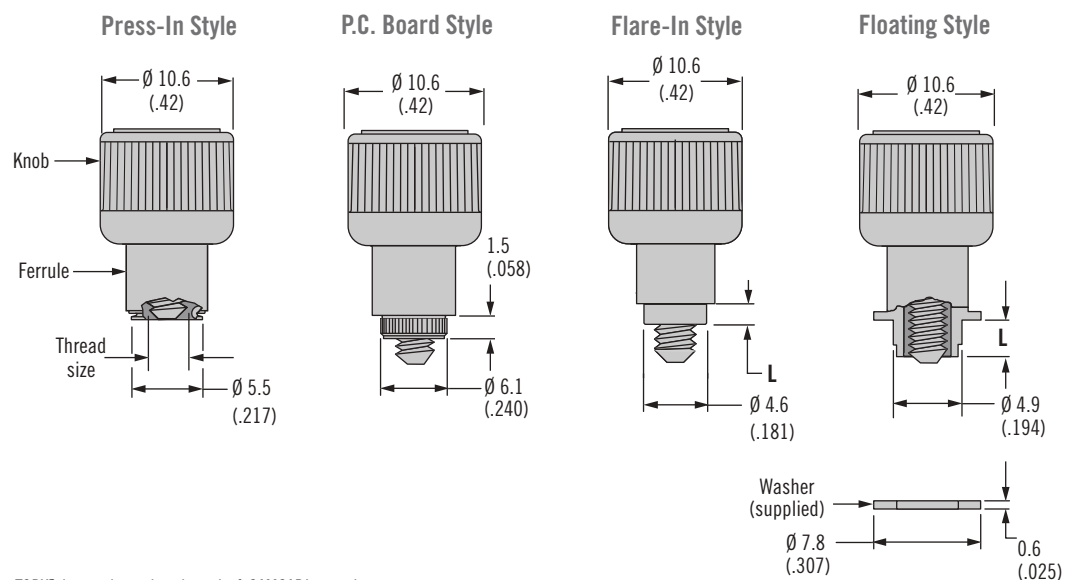

TORX® is a registered trademark of CAMCAR Innovations

Dimensions in millimeters (inch) unless otherwise stated

Installation Style	Knob Height		Outer Panel Dimensions		B	Total Float	Flange Length L	Screw Projection Beyond Outer Surface of Panel		Part Number				
	H-1	H-2	A Min.	A Max.				P-1	P-2	Slotted Recess	Phillips Recess	TORX® Recess	TORX® / Slot Combination	Phillips / Slot Combination
Press-In Style	11.3 (.45)	8.3 (.33)	0.9 (.036)	~	~	0.8 (.03)	~	0.8 (.03)	3.8 (.15)	47-60-101-24	47-60-121-24	47-60-141-24	47-60-161-20	47-60-181-24
								2.5 (.10)	5.5 (.22)	47-61-101-24	47-61-121-24	47-61-141-24	47-61-161-20	47-61-181-24
								4 (.16)	7 (.28)	47-62-101-24	47-62-121-24	47-62-141-24	47-62-161-20	47-62-181-24
								5.6 (.22)	8.6 (.34)	47-63-101-24	47-63-121-24	47-63-141-24	47-63-161-20	47-63-181-24
P.C. Board Style	11.5 (.45)	8.3 (.33)	1.6 (.061)	~	~	0.8 (.03)	~	1.5 (.06)	4.5 (.18)	47-65-101-34	47-65-121-34	47-65-141-34	47-65-161-30	47-65-181-34
Flare-In Style	11.5 (.45)	8.1 (.32)	0.8 (.031)	1.5 (.058)	0.4 (.015)	0.6 (.03)	1 (.041)	0.8 (.03)	4 (.16)	47-10-101-14	47-10-121-14	47-10-141-14	47-10-161-10	47-10-181-14
			1.5 (.059)	2.5 (.100)	0.4 (.015)		1.8 (.070)	1.5 (.06)	4.7 (.19)	47-10-102-14	47-10-122-14	47-10-142-14	47-10-162-10	47-10-182-14
			2.5 (.1)	4 (.156)	0.8 (.031)		2.6 (.104)	2.5 (.10)	5.7 (.22)	47-10-103-14	47-10-123-14	47-10-143-14	47-10-163-10	47-10-183-14
			4 (.157)	5.6 (.219)	2.4 (.093)		4.2 (.166)	4 (.16)	7.2 (.28)	47-10-105-14	47-10-125-14	47-10-145-14	47-10-165-10	47-10-185-14
			5.6 (.220)	7.1 (.281)	4 (.156)		5.8 (.229)	5.6 (.22)	8.8 (.35)	47-10-107-14	47-10-127-14	47-10-147-14	47-10-167-10	47-10-187-14
			0.8 (.031)	1.5 (.058)	0.4 (.015)		1 (.041)	2.5 (.10)	5.7 (.22)	47-11-101-14	47-11-121-14	47-11-141-14	47-11-161-10	47-11-181-14
			4 (.16)	7.2 (.28)	47-12-101-14			47-12-121-14	47-12-141-14	47-12-161-10	47-12-181-14			
			5.6 (.22)	8.8 (.35)	47-13-101-14			47-13-121-14	47-13-141-14	47-13-161-10	47-13-181-14			
			1.8 (.070)	3.2 (.13)	6.4 (.25)		47-11-102-14	47-11-122-14	47-11-142-14	47-11-162-10	47-11-182-14			
				4.7 (.19)	7.9 (.31)		47-12-102-14	47-12-122-14	47-12-142-14	47-12-162-10	47-12-182-14			
				6.3 (.25)	9.5 (.37)		47-13-102-14	47-13-122-14	47-13-142-14	47-13-162-10	47-13-182-14			
			Floating Style	11.4 (.45)	8.6 (.34)		~	0.8 (.031)	2 (.080)	2.1 (.08)	2.6 (.101)	1.9 (.07)	5.1 (.20)	47-10-110-14
3.4 (.13)	6.6 (.26)	47-11-110-14				47-11-130-14		47-11-150-14	47-11-170-10		47-11-190-14			
5 (.19)	8.2 (.32)	47-12-110-14				47-12-130-14		47-12-150-14	47-12-170-10		47-12-190-14			
0.8 (.031)	1.6 (.063)	2.8 (.111)				3.4 (.132)	1.9 (.07)	5.1 (.20)	47-10-111-14		47-10-131-14	47-10-151-14	47-10-171-10	47-10-191-14
3.4 (.13)	6.6 (.26)	47-11-111-14					47-11-131-14	47-11-151-14	47-11-171-10		47-11-191-14			
5 (.19)	8.2 (.32)	47-12-111-14					47-12-131-14	47-12-151-14	47-12-171-10		47-12-191-14			
1.6 (.063)	2.4 (.094)	3.6 (.143)				4.2 (.164)	3.4 (.13)	6.6 (.26)	47-10-112-14		47-10-132-14	47-10-152-14	47-10-172-10	47-10-192-14
							5 (.19)	8.2 (.32)	47-11-112-14		47-11-132-14	47-11-152-14	47-11-172-10	47-11-192-14

Part numbers in shaded rows (shown in table) are fully retracting in minimum panel thickness 



To add a black powder coated finish, change the part number from the table as shown:

- Change 1 to 5: 47-80-102-14
47-80-102-54
- Change 2 to 6: 47-80-102-24
47-80-102-64
- Change 3 to 7: 47-80-102-34
47-80-102-74



For a smooth knob, change the part number from the table as shown:

- Change 0 to 1: 47-90-161-20
47-90-161-21
- Change 4 to 5: 47-90-101-24
47-90-101-25

Part Number

See table

All screw part numbers shown in table are for a natural knob finish and a knurled knob

For black finish and smooth knob options, minimums may apply



47 Captive Screws

Styled knob series · 6-32 thread size

- Smooth knob meets UL-1950
- Designed for hand operation
- Spring ejected
- Wide variety of sizes, recesses and installation options

Material and Finish

Ferrule:

Press-in: Hardened carbon steel, zinc plate, chromate, plus sealer

P.C. board style: 300 Series

stainless steel, passivated

Flare-in, floating and snap-in:

Aluminum, natural

Knob: Aluminum, natural or black powder coated

Screw: Hardened carbon steel, zinc plated, chromate, plus sealer

Installation Notes

See pages 546-547, 627

Notes



To ensure you receive **SOUTHCO**® quality parts, look for the segmented circle

Recess Styles

Slotted

No. 2 Phillips

T15 TORX®

T15 TORX® /
Slot Combination

No. 2 Phillips /
Slot Combination

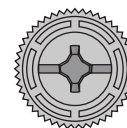
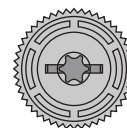
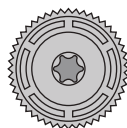
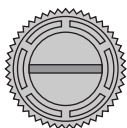

Knob Height and Screw Projection

(Flare-in style shown)

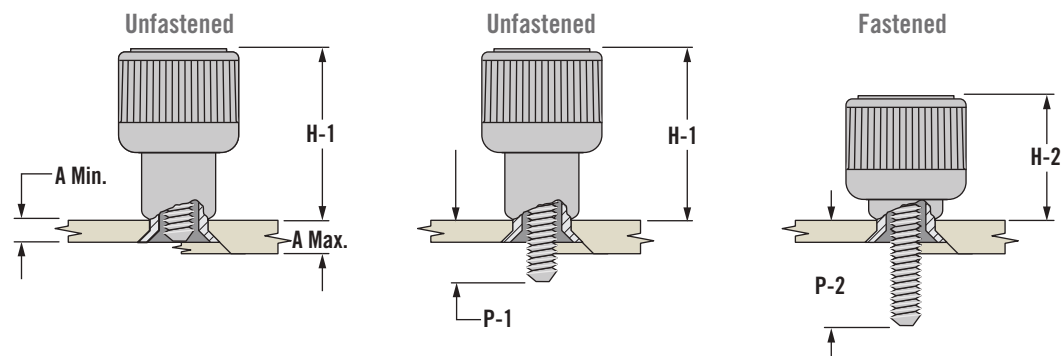

Installation Styles

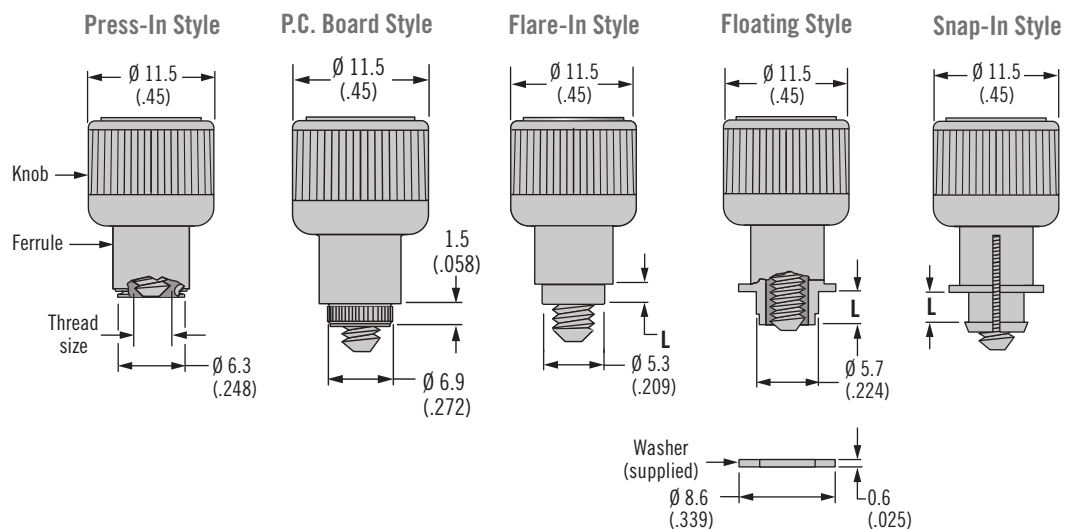

TORX® is a registered trademark of CAMCAR Innovations

Dimensions in millimeters (inch) unless otherwise stated

Installation Style	Knob Height		Outer Panel Dimensions		B	Total Float	Flange Length L	Screw Projection Beyond Outer Surface of Panel		Part Number				
	H-1	H-2	A Min.	A Max.				P-1	P-2	Slotted Recess	Phillips Recess	TORX® Recess	TORX® / Slot Combination	Phillips / Slot Combination
Press-In Style	15.9 (.63)	11.2 (.44)	0.9 (.036)	~	~	0.8 (.03)	~	0.5 (.02)	5.3 (.21)	47-60-201-24	47-60-221-24	47-60-241-24	47-60-261-20	47-60-281-24
								2.1 (.08)	6.9 (.27)	47-61-201-24	47-61-221-24	47-61-241-24	47-61-261-20	47-61-281-24
								3.7 (.15)	8.5 (.33)	47-62-201-24	47-62-221-24	47-62-241-24	47-62-261-20	47-62-281-24
								5.3 (.21)	10.1 (.40)	47-63-201-24	47-63-221-24	47-63-241-24	47-63-261-20	47-63-281-24
P.C. Board Style	14.8 (.58)	10 (.39)	1.6 (.061)	~	~	0.8 (.03)	~	1.4 (.06)	6.1 (.24)	47-65-201-34	47-65-221-34	47-65-241-34	47-65-261-30	47-65-281-34
Flare-In Style	15.3 (.60)	10.4 (.41)	1.5 (.058)	3.2 (.125)	0.4 (.015)	0.8 (.03)	1.8 (.07)	1.1 (.04)	6 (.24)	47-10-202-14	47-10-222-14	47-10-242-14	47-10-262-10	47-10-282-14
			3.2 (.125)	4.8 (.189)	1.6 (.062)		3.4 (.135)	2.7 (.11)	7.6 (.30)	47-10-204-14	47-10-224-14	47-10-244-14	47-10-264-10	47-10-284-14
			4.8 (.189)	6.4 (.250)	3.2 (.125)		5 (.197)	4.3 (.17)	9.2 (.36)	47-10-206-14	47-10-226-14	47-10-246-14	47-10-266-10	47-10-286-14
			6.4 (.250)	7.9 (.312)	4.8 (.189)		6.1 (.26)	5.9 (.23)	10.8 (.43)	47-10-208-14	47-10-228-14	47-10-248-14	47-10-268-10	47-10-288-14
			1.5 (.058)	3.2 (.125)	0.4 (.015)		1.8 (.07)	2.7 (.11)	7.6 (.30)	47-11-202-14	47-11-222-14	47-11-242-14	47-11-262-10	47-11-282-14
			3.2 (.125)	4.8 (.189)	1.6 (.062)		3.4 (.135)	4.3 (.17)	9.2 (.36)	47-12-202-14	47-12-222-14	47-12-242-14	47-12-262-10	47-12-282-14
			4.8 (.189)	6.4 (.250)	3.2 (.125)		5 (.197)	5.9 (.23)	10.8 (.43)	47-13-202-14	47-13-222-14	47-13-242-14	47-13-262-10	47-13-282-14
			6.4 (.250)	7.9 (.312)	4.8 (.189)		6.1 (.26)	5.9 (.23)	10.8 (.43)	47-12-204-14	47-12-224-14	47-12-244-14	47-12-264-10	47-12-284-14
			1.5 (.058)	3.2 (.125)	0.4 (.015)		1.8 (.07)	2.7 (.11)	7.6 (.30)	47-11-204-14	47-11-224-14	47-11-244-14	47-11-264-10	47-11-284-14
			3.2 (.125)	4.8 (.189)	1.6 (.062)		3.4 (.135)	4.3 (.17)	9.2 (.36)	47-12-204-14	47-12-224-14	47-12-244-14	47-12-264-10	47-12-284-14
4.8 (.189)	6.4 (.250)	3.2 (.125)	5 (.197)	5.9 (.23)	10.8 (.43)	47-11-206-14	47-11-226-14	47-11-246-14	47-11-266-10	47-11-286-14				
Floating Style	15.3 (.60)	10.6 (.42)	~	0.8 (.031)	2.1 (.083)	2.2 (.09)	2.9 (.113)	2.4 (.09)	7.2 (.28)	47-10-210-14	47-10-230-14	47-10-250-14	47-10-270-10	47-10-290-14
			0.8 (.031)	1.6 (.063)	2.9 (.114)		3.7 (.144)	4 (.16)	8.8 (.35)	47-11-210-14	47-11-230-14	47-11-250-14	47-11-270-10	47-11-290-14
			1.6 (.063)	2.4 (.094)	3.7 (.146)		4.5 (.176)	4 (.16)	8.8 (.35)	47-10-212-14	47-10-232-14	47-10-252-14	47-10-272-10	47-10-292-14
			~	0.8 (.031)	2.1 (.083)		2.9 (.113)	2.4 (.09)	7.2 (.28)	47-10-211-14	47-10-231-14	47-10-251-14	47-10-271-10	47-10-291-14
			0.8 (.031)	1.6 (.063)	2.9 (.114)		3.7 (.144)	4 (.16)	8.8 (.35)	47-11-211-14	47-11-231-14	47-11-251-14	47-11-271-10	47-11-291-14
			1.6 (.063)	2.4 (.094)	3.7 (.146)		4.5 (.176)	4 (.16)	8.8 (.35)	47-12-211-14	47-12-231-14	47-12-251-14	47-12-271-10	47-12-291-14
Snap-In Style	15.3 (.60)	10.6 (.42)	0.5 (.020)	1 (.039)	2 (.079)	0.8 (.03)	1.1 (.044)	0.8 (.03)	5.6 (.22)	47-60-210-14	47-60-230-14	47-60-250-14	47-60-270-10	47-60-290-14
			1 (.039)	1.6 (.063)	2.6 (.103)		1.7 (.067)	2.4 (.09)	7.2 (.28)	47-61-210-14	47-61-230-14	47-61-250-14	47-61-270-10	47-61-290-14
			0.5 (.020)	1 (.039)	2 (.079)		1.1 (.044)	4 (.16)	8.8 (.35)	47-62-210-14	47-62-230-14	47-62-250-14	47-62-270-10	47-62-290-14
			1 (.039)	1.6 (.063)	2.6 (.103)		1.7 (.067)	5.6 (.22)	10.4 (.41)	47-63-210-14	47-63-230-14	47-63-250-14	47-63-270-10	47-63-290-14
			0.5 (.020)	1 (.039)	2 (.079)		1.1 (.044)	2.4 (.09)	7.2 (.28)	47-60-212-14	47-60-232-14	47-60-252-14	47-60-272-10	47-60-292-14
			1 (.039)	1.6 (.063)	2.6 (.103)		1.7 (.067)	4 (.16)	8.8 (.35)	47-61-212-14	47-61-232-14	47-61-252-14	47-61-272-10	47-61-292-14
			0.5 (.020)	1 (.039)	2 (.079)		1.1 (.044)	5.6 (.22)	10.4 (.41)	47-62-212-14	47-62-232-14	47-62-252-14	47-62-272-10	47-62-292-14
			1 (.039)	1.6 (.063)	2.6 (.103)		1.7 (.067)	2.4 (.09)	7.2 (.28)	47-60-210-14	47-60-230-14	47-60-250-14	47-60-270-10	47-60-290-14
			0.5 (.020)	1 (.039)	2 (.079)		1.1 (.044)	4 (.16)	8.8 (.35)	47-61-210-14	47-61-230-14	47-61-250-14	47-61-270-10	47-61-290-14
			1 (.039)	1.6 (.063)	2.6 (.103)		1.7 (.067)	5.6 (.22)	10.4 (.41)	47-62-210-14	47-62-230-14	47-62-250-14	47-62-270-10	47-62-290-14

Part numbers in shaded rows (shown in table) are fully retracting in minimum panel thickness



To add a black powder coated finish, change the part number from the table as shown:

- Change 1 to 5: 47-80-102-14
47-80-102-54
- Change 2 to 6: 47-80-102-24
47-80-102-64
- Change 3 to 7: 47-80-102-34
47-80-102-74



For a smooth knob, change the part number from the table as shown:

- Change 0 to 1: 47-90-161-20
47-90-161-21
- Change 4 to 5: 47-90-101-24
47-90-101-25

Part Number

See table

All screw part numbers shown in table are for a natural knob finish and a knurled knob

For black finish and smooth knob options, minimums may apply



47 Captive Screws

Styled knob series · 8-32 thread size

- Designed for hand operation
- Spring ejected
- Wide variety of sizes, recesses and installation options

Material and Finish

Ferrule:

Press-in: Hardened carbon steel, zinc plate, chromate, plus sealer

Flare-in, floating and snap-in: Aluminum, natural

Knob: Aluminum, natural or black powder coated

Screw: Hardened carbon steel, zinc plated, chromate, plus sealer

Installation Notes

See pages 546-547, 627

Notes



To ensure you receive **SOUTHCO®** quality parts, look for the segmented circle

Recess Styles

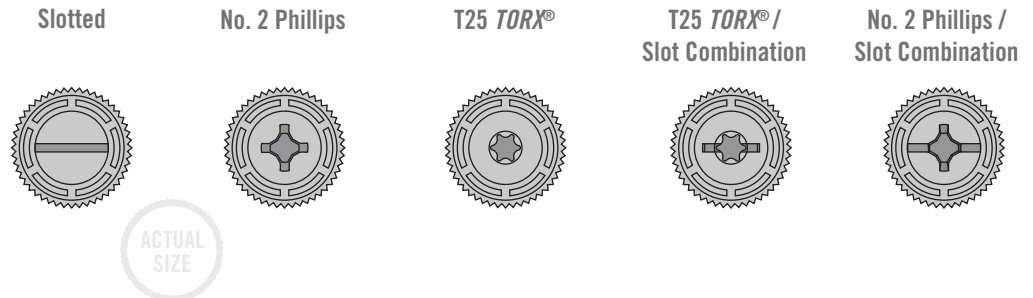

Knob Height and Screw Projection

(Flare-in style shown)

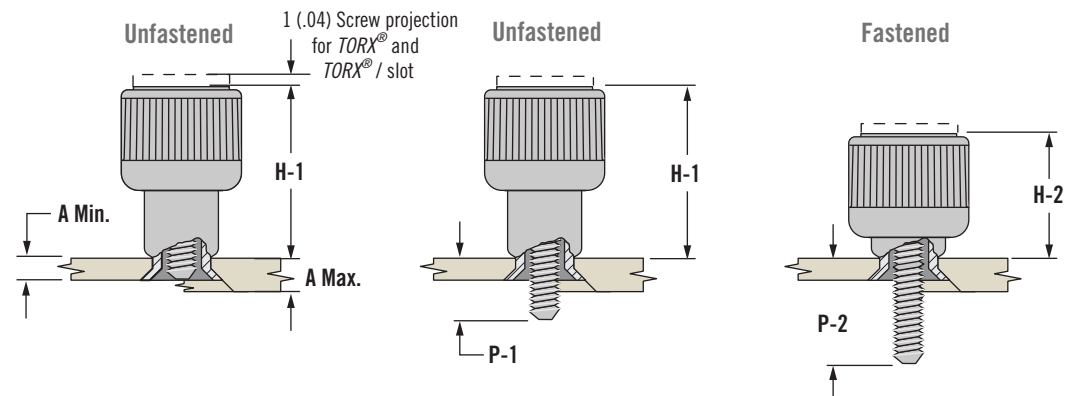

Installation Styles

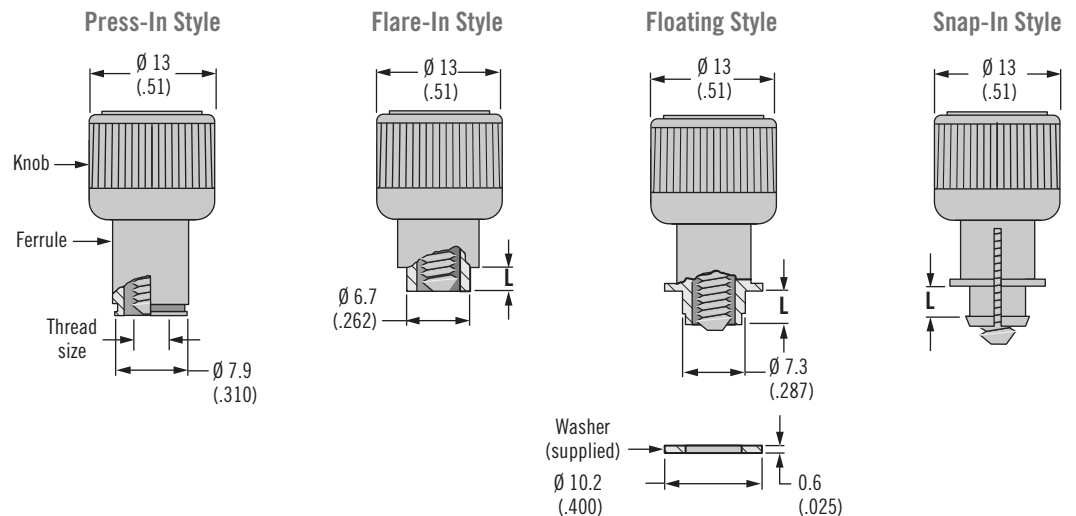

TORX® is a registered trademark of CAMCAR Innovations

Dimensions in millimeters (inch) unless otherwise stated

Installation Style	Knob Height		Outer Panel Dimensions		B	Total Float	Flange Length L	Screw Projection Beyond Outer Surface of Panel		Part Number								
	H-1	H-2	A Min.	A Max.				P-1	P-2	Slotted Recess	Phillips Recess	TORX® Recess	TORX® / Slot Combination	Phillips / Slot Combination				
Press-In Style	16.2 (.64)	11.2 (.44)	0.9 (.036)	~	~	0.8 (.03)	~	0.5 (.02)	5.6 (.22)	47-60-301-24	47-60-321-24	47-60-341-20	47-60-361-20	47-60-381-20				
								2 (.08)	7.1 (.28)	47-61-301-24	47-61-321-24	47-61-341-20	47-61-361-20	47-61-381-20				
								3.8 (.15)	8.9 (.35)	47-62-301-24	47-62-321-24	47-62-341-20	47-62-361-20	47-62-381-20				
								5.3 (.21)	10.4 (.41)	47-63-301-24	47-63-321-24	47-63-341-20	47-63-361-20	47-63-381-20				
Flare-In Style	15.6 (.61)	10.5 (.41)	1.5 (.058)	3.2 (.125)	0.4 (.015)	0.9 (.03)	1.8 (.070)	1 (.04)	6 (.24)	47-10-302-14	47-10-322-14	47-10-342-10	47-10-362-10	47-10-382-10				
			3.2 (.126)	4.8 (.189)	1.6 (.062)		3.4 (.135)	2.8 (.11)	7.6 (.3)	47-10-304-14	47-10-324-14	47-10-344-10	47-10-364-10	47-10-384-10				
			4.8 (.189)	6.4 (.250)	3.2 (.125)		5 (.197)	4.3 (.17)	9.2 (.36)	47-10-306-14	47-10-326-14	47-10-346-10	47-10-366-10	47-10-386-10				
			6.3 (.251)	7.9 (.312)	4.8 (.189)		6.6 (.260)	5.8 (.23)	10.8 (.43)	47-10-308-14	47-10-328-14	47-10-348-10	47-10-368-10	47-10-388-10				
			1.5 (.058)	3.2 (.125)	0.4 (.015)		1.8 (.07)	2.8 (.11)	7.6 (.3)	47-11-302-14	47-11-322-14	47-11-342-10	47-11-362-10	47-11-382-10				
			3.2 (.126)	4.8 (.189)	1.6 (.062)		3.4 (.135)	4.3 (.17)	9.2 (.36)	47-12-302-14	47-12-322-14	47-12-342-10	47-12-362-10	47-12-382-10				
			4.8 (.189)	6.4 (.250)	3.2 (.125)		5 (.197)	5.8 (.23)	10.8 (.43)	47-13-302-14	47-13-322-14	47-13-342-10	47-13-362-10	47-13-382-10				
			1.5 (.058)	3.2 (.125)	0.4 (.015)		1.8 (.07)	2.8 (.11)	7.6 (.3)	47-11-304-14	47-11-324-14	47-11-344-10	47-11-364-10	47-11-384-10				
			3.2 (.126)	4.8 (.189)	1.6 (.062)		3.4 (.135)	4.3 (.17)	9.2 (.36)	47-12-304-14	47-12-324-14	47-12-344-10	47-12-364-10	47-12-384-10				
			4.8 (.189)	6.4 (.250)	3.2 (.125)		5 (.197)	5.8 (.23)	10.8 (.43)	47-11-306-14	47-11-326-14	47-11-346-10	47-11-366-10	47-11-386-10				
			Floating Style	16 (.63)	11.2 (.44)		~	0.8 (.031)	2.3 (.09)	2.3 (.09)	3.2 (.127)	2.3 (.09)	7.1 (.28)	47-10-310-14	47-10-330-14	47-10-350-10	47-10-370-10	47-10-390-10
							0.8 (.031)	1.6 (.063)	3.1 (.121)		3.8 (.15)	8.9 (.35)	47-11-310-14	47-11-330-14	47-11-350-10	47-11-370-10	47-11-390-10	
1.6 (.063)	2.4 (.094)	3.9 (.153)				5.6 (.22)	10.4 (.41)	47-12-310-14	47-12-330-14		47-12-350-10	47-12-370-10	47-12-390-10					
~	0.8 (.031)	2.3 (.09)				4 (158)	2.3 (.09)	7.1 (.28)	47-10-311-14		47-10-331-14	47-10-351-10	47-10-371-10	47-10-391-10				
0.8 (.031)	1.6 (.063)	3.1 (.121)				4 (158)	3.8 (.15)	8.9 (.35)	47-11-311-14		47-11-331-14	47-11-351-10	47-11-371-10	47-11-391-10				
1.6 (.063)	2.4 (.094)	3.9 (.153)				4 (158)	5.6 (.22)	10.4 (.41)	47-12-311-14		47-12-331-14	47-12-351-10	47-12-371-10	47-12-391-10				
~	0.8 (.031)	2.3 (.09)				4.8 (190)	3.8 (.15)	8.9 (.35)	47-10-312-14		47-10-332-14	47-10-352-10	47-10-372-10	47-10-392-10				
0.8 (.031)	1.6 (.063)	3.1 (.121)				4.8 (190)	5.6 (.22)	10.4 (.41)	47-11-312-14		47-11-332-14	47-11-352-10	47-11-372-10	47-11-392-10				
1.6 (.063)	2.4 (.094)	3.9 (.153)				4.8 (190)	3.8 (.15)	8.9 (.35)	47-10-314-14		47-10-334-14	47-10-354-10	47-10-374-10	47-10-394-10				
0.8 (.031)	1.6 (.063)	3.1 (.121)				4.8 (190)	5.6 (.22)	10.4 (.41)	47-11-314-14		47-11-334-14	47-11-354-10	47-11-374-10	47-11-394-10				
Snap-In Style	15.7 (.62)	11.2 (.44)				0.5 (.020)	1 (.039)	2 (.079)	0.9 (.03)		1.1 (.044)	1 (.04)	3 (.22)	47-60-310-14	47-60-330-14	47-60-350-10	47-60-370-10	47-60-390-10
						1 (.039)	1.6 (.063)	2.6 (.103)			1.1 (.044)	2.8 (.11)	7.1 (.28)	47-61-310-14	47-61-330-14	47-61-350-10	47-61-370-10	47-61-390-10
			1.6 (.063)	2.5 (.098)	3.5 (.138)	1.1 (.044)	4.3 (.17)	8.9 (.35)		47-63-310-14	47-63-330-14	47-63-350-10	47-63-370-10	47-63-390-10				
			0.5 (.020)	1 (.039)	2 (.079)	1.1 (.044)	5.8 (.23)	10.4 (.41)		47-63-310-14	47-63-330-14	47-63-350-10	47-63-370-10	47-63-390-10				
			1 (.039)	1.6 (.063)	2.6 (.103)	1.7 (.068)	2.8 (.11)	7.1 (.28)		47-60-312-14	47-60-332-14	47-60-352-10	47-60-372-10	47-60-392-10				
			1.6 (.063)	2.5 (.098)	3.5 (.138)	1.7 (.068)	4.3 (.17)	8.9 (.35)		47-61-312-14	47-61-332-14	47-61-352-10	47-61-372-10	47-61-392-10				
			0.5 (.020)	1 (.039)	2 (.079)	1.7 (.068)	5.8 (.23)	10.4 (.41)		47-62-312-14	47-62-332-14	47-62-352-10	47-62-372-10	47-62-392-10				
			1 (.039)	1.6 (.063)	2.6 (.103)	1.7 (.068)	2.8 (.11)	7.1 (.28)		47-60-314-14	47-60-334-14	47-60-354-10	47-60-374-10	47-60-394-10				
			1.6 (.063)	2.5 (.098)	3.5 (.138)	1.7 (.068)	4.3 (.17)	8.9 (.35)		47-61-314-14	47-61-334-14	47-61-354-10	47-61-374-10	47-61-394-10				
			0.5 (.020)	1 (.039)	2 (.079)	1.7 (.068)	5.8 (.23)	10.4 (.41)		47-62-314-14	47-62-334-14	47-62-354-10	47-62-374-10	47-62-394-10				
			1 (.039)	1.6 (.063)	2.6 (.103)	2.6 (.103)	5.8 (.23)	10.4 (.41)		47-62-314-14	47-62-334-14	47-62-354-10	47-62-374-10	47-62-394-10				

Part numbers in shaded rows (shown in table) are fully retracting in minimum panel thickness



To add a black powder coated finish, change the part number from the table as shown:

- Change 1 to 5: 47-80-102-14
- 47-80-102-54
- Change 2 to 6: 47-80-102-24
- 47-80-102-64



For a smooth knob, change the part number from the table as shown:

- Change 0 to 1: 47-90-161-20
- 47-90-161-21
- Change 4 to 5: 47-90-101-24
- 47-90-101-25

Part Number

See table

All screw part numbers shown in table are for a natural knob finish and a knurled knob

For black finish and smooth knob options, minimums may apply



47 Captive Screws

Styled knob series · 10-32 thread size

- Designed for hand operation
- Spring ejected
- Wide variety of sizes, recesses and installation options

Material and Finish

Ferrule:

Press-in: Hardened carbon steel, zinc plate, chromate, plus sealer

Flare-in, floating and snap-in:

Aluminum, natural

Knob: Aluminum, natural or black powder coated

Screw: Hardened carbon steel, zinc plated, chromate, plus sealer

Installation Notes

See pages 546-547, 627

Notes



To ensure you receive **SOUTHCO®** quality parts, look for the segmented circle

Recess Styles

Slotted

No. 2 Phillips

T25 TORX®

T25 TORX® /
Slot Combination

No. 2 Phillips /
Slot Combination

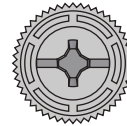
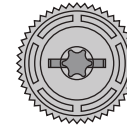
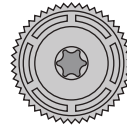
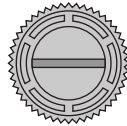

Knob Height and Screw Projection

(Flare-in style shown)

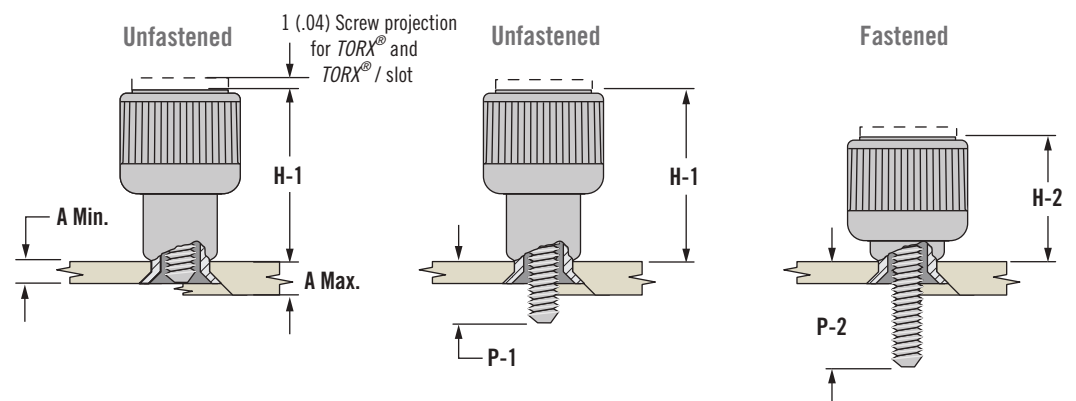

Installation Styles

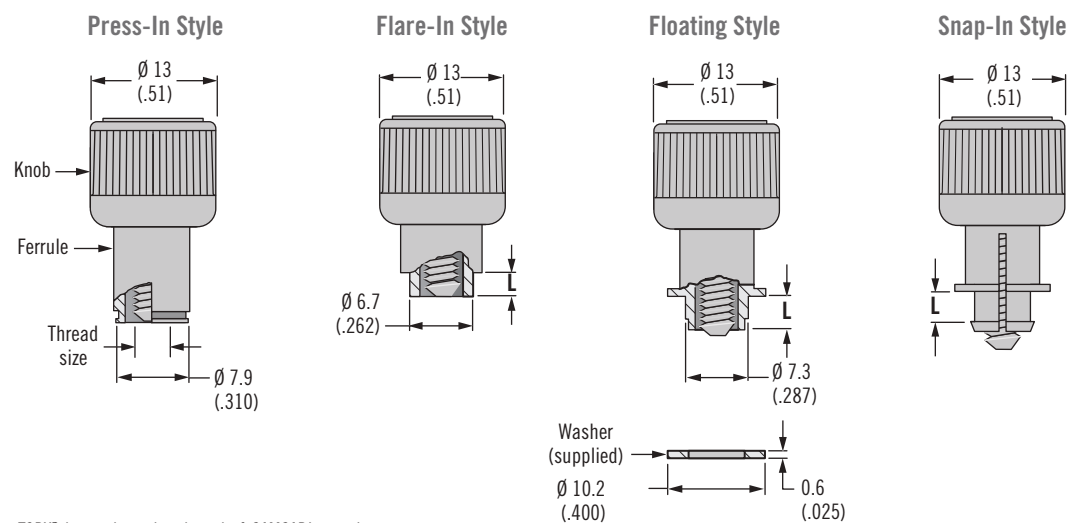

TORX® is a registered trademark of CAMCAR Innovations

Dimensions in millimeters (inch) unless otherwise stated

Installation Style	Knob Height		Outer Panel Dimensions		B	Total Float	Flange Length L	Screw Projection Beyond Outer Surface of Panel		Part Number				
	H-1	H-2	A Min.	A Max.				P-1	P-2	Slotted Recess	Phillips Recess	TORX® Recess	TORX® / Slot Combination	Phillips / Slot Combination
Press-In Style	16.2 (.64)	11.2 (.44)	0.9 (.036)	~	~	0.6 (.02)	~	0.6 (.02)	5.5 (.22)	47-60-501-24	47-60-521-24	47-60-541-20	47-60-561-20	47-60-581-20
								2.2 (.09)	7.2 (.28)	47-61-501-24	47-61-521-24	47-61-541-20	47-61-561-20	47-61-581-20
								3.8 (.15)	8.9 (.35)	47-62-501-24	47-62-521-24	47-62-541-20	47-62-561-20	47-62-581-20
								5.4 (.21)	10.3 (.41)	47-63-501-24	47-63-521-24	47-63-541-20	47-63-561-20	47-63-581-20
Flare-In Style	15.6 (.61)	10.5 (.41)	1.5 (.058)	3.2 (.125)	0.4 (.015)	0.6 (.02)	1.8 (.070)	1.2 (.05)	6.3 (.25)	47-10-502-14	47-10-522-14	47-10-542-10	47-10-562-10	47-10-582-10
			3.2 (.125)	4.7 (.187)	1.6 (.062)		3.4 (.135)	2.8 (.11)	7.9 (.31)	47-10-504-14	47-10-524-14	47-10-544-10	47-10-564-10	47-10-584-10
			4.8 (.189)	6.4 (.250)	3.2 (.125)		5 (.197)	4.4 (.17)	9.5 (.37)	47-10-506-14	47-10-526-14	47-10-546-10	47-10-566-10	47-10-586-10
			6.3 (.251)	7.9 (.312)	4.8 (.187)		6.6 (.260)	6 (.24)	11.1 (.44)	47-10-508-14	47-10-528-14	47-10-548-10	47-10-568-10	47-10-588-10
			1.5 (.058)	3.2 (.125)	0.4 (.015)		1.8 (.070)	2.8 (.11)	7.9 (.31)	47-11-502-14	47-11-522-14	47-11-542-10	47-11-562-10	47-11-582-10
			3.2 (.125)	4.8 (.187)	1.6 (.062)		3.4 (.135)	4.4 (.17)	9.5 (.37)	47-12-502-14	47-12-522-14	47-12-542-10	47-12-562-10	47-12-582-10
			4.8 (.189)	6.4 (.250)	3.2 (.125)		5 (.197)	4.4 (.17)	9.5 (.37)	47-11-504-14	47-11-524-14	47-11-544-10	47-11-564-10	47-11-584-10
			6.3 (.251)	7.9 (.312)	4.8 (.187)		6.6 (.260)	6 (.24)	11.1 (.44)	47-12-504-14	47-12-524-14	47-12-544-10	47-12-564-10	47-12-584-10
			1.5 (.058)	3.2 (.125)	0.4 (.015)		1.8 (.070)	2.8 (.11)	7.9 (.31)	47-11-506-14	47-11-526-14	47-11-546-10	47-11-566-10	47-11-586-10
			3.2 (.125)	4.8 (.187)	1.6 (.062)		3.4 (.135)	4.4 (.17)	9.5 (.37)	47-11-508-14	47-11-528-14	47-11-548-10	47-11-568-10	47-11-588-10
Floating Style	16 (.63)	11.2 (.44)	~	0.8 (.031)	2.3 (.090)	2.3 (.09)	3.2 (.127)	2.3 (.09)	7.1 (.28)	47-10-510-14	47-10-530-14	47-10-550-10	47-10-570-10	47-10-590-10
			0.8 (.031)	1.6 (.063)	3.1 (.122)		4 (.158)	4 (.16)	8.8 (.35)	47-11-510-14	47-11-530-14	47-11-550-10	47-11-570-10	47-11-590-10
			1.6 (.063)	2.4 (.094)	3.9 (.153)		4 (.158)	5.6 (.22)	10.4 (.41)	47-12-510-14	47-12-530-14	47-12-550-10	47-12-570-10	47-12-590-10
			~	0.8 (.031)	2.3 (.090)		4 (.158)	2.4 (.09)	7.1 (.28)	47-10-511-14	47-10-531-14	47-10-551-10	47-10-571-10	47-10-591-10
			0.8 (.031)	1.6 (.063)	3.1 (.122)		4 (.158)	4 (.16)	8.8 (.35)	47-11-511-14	47-11-531-14	47-11-551-10	47-11-571-10	47-11-591-10
			1.6 (.063)	2.4 (.094)	3.9 (.153)		4 (.158)	5.6 (.22)	10.4 (.41)	47-12-511-14	47-12-531-14	47-12-551-10	47-12-571-10	47-12-591-10
			~	0.8 (.031)	2.3 (.090)		4.8 (.190)	4 (.16)	8.8 (.35)	47-10-512-14	47-10-532-14	47-10-552-10	47-10-572-10	47-10-592-10
			0.8 (.031)	1.6 (.063)	3.1 (.122)		4.8 (.190)	5.6 (.22)	10.4 (.41)	47-11-512-14	47-11-532-14	47-11-552-10	47-11-572-10	47-11-592-10
			1.6 (.063)	2.4 (.094)	3.9 (.153)		4.8 (.190)	5.6 (.22)	10.4 (.41)	47-12-512-14	47-12-532-14	47-12-552-10	47-12-572-10	47-12-592-10
			Snap-In Style	15.7 (.62)	11.2 (.44)		0.5 (.020)	1 (.039)	2 (.079)	.9 (.04)	1.1 (.044)	1.2 (.04)	5.6 (.22)	47-60-510-14
0.5 (.020)	1 (.039)	2 (.079)				1.1 (.044)	2.8 (.11)	7.1 (.28)	47-61-510-14		47-61-530-14	47-61-550-10	47-61-570-10	47-61-590-10
0.5 (.020)	1 (.039)	2 (.079)				1.1 (.044)	4.3 (.17)	8.8 (.35)	47-63-510-14		47-63-530-14	47-63-550-10	47-63-570-10	47-63-590-10
0.5 (.020)	1 (.039)	2 (.079)				1.1 (.044)	5.9 (.23)	10.4 (.41)	47-63-510-14		47-63-530-14	47-63-550-10	47-63-570-10	47-63-590-10
1 (.039)	1.6 (.063)	2.6 (.103)				1.7 (.068)	2.8 (.11)	7.1 (.28)	47-60-512-14		47-60-532-14	47-60-552-10	47-60-572-10	47-60-592-10
1 (.039)	1.6 (.063)	2.6 (.103)				1.7 (.068)	4.3 (.17)	8.8 (.35)	47-61-512-14		47-61-532-14	47-61-552-10	47-61-572-10	47-61-592-10
1 (.039)	1.6 (.063)	2.6 (.103)				1.7 (.068)	5.9 (.23)	10.4 (.41)	47-62-512-14		47-62-532-14	47-62-552-10	47-62-572-10	47-62-592-10
1.6 (.063)	2.5 (.098)	3.5 (.138)				2.6 (.103)	2.8 (.11)	7.1 (.28)	47-60-514-14		47-60-534-14	47-60-554-10	47-60-574-10	47-60-594-10
1.6 (.063)	2.5 (.098)	3.5 (.138)				2.6 (.103)	4.3 (.17)	8.8 (.35)	47-61-514-14		47-61-534-14	47-61-554-10	47-61-574-10	47-61-594-10
1.6 (.063)	2.5 (.098)	3.5 (.138)				2.6 (.103)	5.9 (.23)	10.4 (.41)	47-62-514-14		47-62-534-14	47-62-554-10	47-62-574-10	47-62-594-10
1.6 (.063)	2.5 (.098)	3.5 (.138)				2.6 (.103)	5.9 (.23)	10.4 (.41)	47-62-514-14		47-62-534-14	47-62-554-10	47-62-574-10	47-62-594-10

Part numbers in shaded rows (shown in table) are fully retracting in minimum panel thickness



To add a black powder coated finish, change the part number from the table as shown:

- Change 1 to 5: 47-80-102-14
- 47-80-102-54
- Change 2 to 6: 47-80-102-24
- 47-80-102-64



For a smooth knob, change the part number from the table as shown:

- Change 0 to 1: 47-90-161-20
- 47-90-161-21
- Change 4 to 5: 47-90-101-24
- 47-90-101-25

Part Number

See table

All screw part numbers shown in table are for a natural knob finish and a knurled knob

For black finish and smooth knob options, minimums may apply



47 Captive Screws

Styled knob series · 1/4-20 thread size

- Designed for hand operation
- Spring ejected
- Wide variety of sizes, recesses and installation options

Material and Finish

Ferrule:

Press-in: Hardened carbon steel, zinc plate, chromate, plus sealer
Flare-in and Floating: Aluminum, natural

Knob: Aluminum, natural or black powder coated

Screw: Hardened carbon steel, zinc plated, chromate, plus sealer

Installation Notes

See pages 546-547, 627

Notes



To ensure you receive **SOUTHCO®** quality parts, look for the segmented circle

RecessStyles



Knob Height and Screw Projection

(Flare-in style shown)

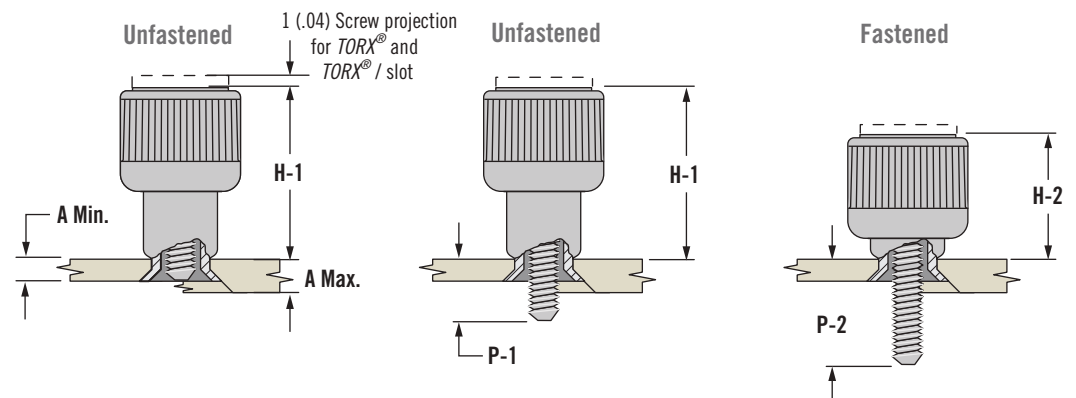

Installation Styles

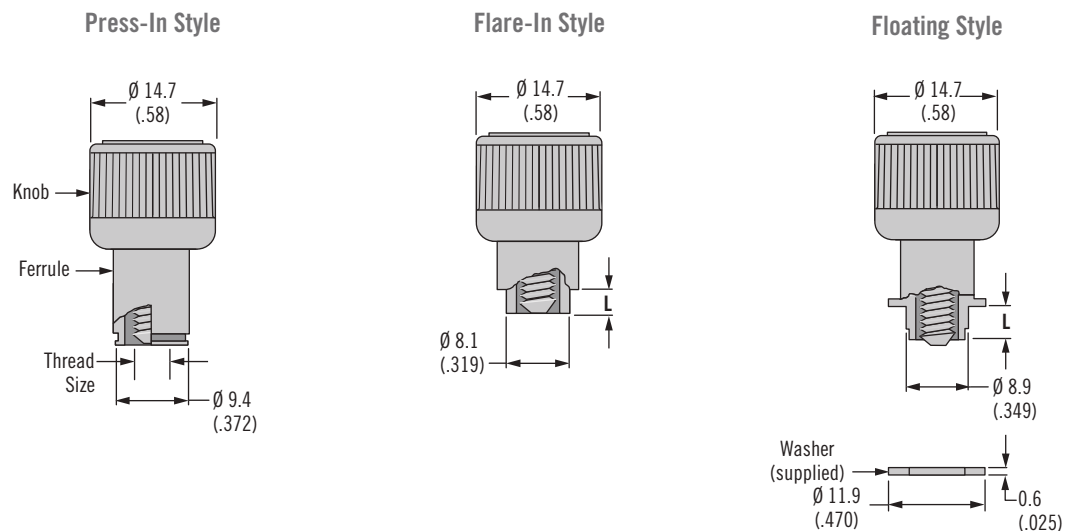

TORX® is a registered trademark of CAMCAR Innovations

Dimensions in millimeters (inch) unless otherwise stated

Installation Style	Knob Height		Outer Panel Dimensions		B	Total Float	Flange Length L	Screw Projection Beyond Outer Surface of Panel		Part Number								
	H-1	H-2	A Min.	A Max.				P-1	P-2	Slotted Recess	Phillips Recess	TORX® Recess	TORX® / Slot Combination	Phillips / Slot Combination				
Press-In Style	20 (.79)	13.4 (.53)	0.9 (.036)	~	~	0.8 (.03)	~	0.5 (.02)	7.1 (.28)	47-60-601-24	47-60-621-24	47-60-641-20	47-60-661-20	47-60-681-20				
								2.1 (.08)	8.7 (.34)	47-61-601-24	47-61-621-24	47-61-641-20	47-61-661-20	47-61-681-20				
								3.7 (.15)	10.3 (.41)	47-62-601-24	47-62-621-24	47-62-641-20	47-62-661-20	47-62-681-20				
								5.3 (.21)	11.9 (.47)	47-63-601-24	47-63-621-24	47-63-641-20	47-63-661-20	47-63-681-20				
Flare-In Style	19.3 (.76)	12.7 (.50)	1.5 (.058)	3.2 (.125)	0.4 (.015)	0.9 (.03)	1.8 (.070)	1.2 (.05)	7.8 (.31)	47-10-602-14	47-10-622-14	47-10-642-10	47-10-662-10	47-10-682-10				
			3.2 (.126)	4.8 (.189)	1.6 (.062)		3.4 (.135)	2.8 (.11)	9.4 (.37)	47-10-604-14	47-10-624-14	47-10-644-10	47-10-664-10	47-10-684-10				
			4.8 (.188)	6.4 (.250)	3.2 (.125)		5 (.197)	4.4 (.17)	11 (.43)	47-10-606-14	47-10-626-14	47-10-646-10	47-10-666-10	47-10-686-10				
			6.4 (.251)	7.9 (.312)	4.8 (.189)		6.6 (.260)	6 (.24)	12.6 (.50)	47-10-608-14	47-10-628-14	47-10-648-10	47-10-668-10	47-10-688-10				
			1.5 (.058)	3.2 (.125)	0.4 (.015)		1.8 (.070)	2.8 (.11)	9.4 (.37)	47-11-602-14	47-11-622-14	47-11-642-10	47-11-662-10	47-11-682-10				
			4.4 (.17)	11 (.43)	47-12-602-14		47-12-622-14	47-12-642-10	47-12-662-10	47-12-682-10								
			6 (.24)	12.6 (.50)	47-13-602-14		47-13-622-14	47-13-642-10	47-13-662-10	47-13-682-10								
			3.2 (.126)	4.8 (.189)	1.6 (.062)		3.4 (.135)	4.4 (.17)	11 (.43)	47-11-604-14	47-11-624-14	47-11-644-10	47-11-664-10	47-11-684-10				
			6 (.24)	12.6 (.50)	47-12-604-14		47-12-624-14	47-12-644-10	47-12-664-10	47-12-684-10								
			4.8 (.189)	6.4 (.250)	3.2 (.125)		5 (.197)	6 (.24)	12.6 (.50)	47-11-606-14	47-11-626-14	47-11-646-10	47-11-666-10	47-11-686-10				
			Floating Style	20 (.79)	13.3 (.52)		~	0.8 (.031)	2.3 (.090)	2.3 (.09)	3.2 (.127)	2.1 (.08)	8.8 (.35)	47-10-610-14	47-10-630-14	47-10-650-10	47-10-670-10	47-10-690-10
							0.8 (.031)	1.6 (.063)	3.1 (.122)		4 (.158)	3.7 (.15)	10.4 (.41)	47-11-610-14	47-11-630-14	47-11-650-10	47-11-670-10	47-11-690-10
5.3 (.21)	12 (.47)	47-12-610-14				47-12-630-14	47-12-650-10	47-12-670-10	47-12-690-10									
2.1 (.08)	8.8 (.35)	47-10-611-14				47-10-631-14	47-10-651-10	47-10-671-10	47-10-691-10									
3.7 (.15)	10.4 (.41)	47-11-611-14				47-11-631-14	47-11-651-10	47-11-671-10	47-11-691-10									
5.3 (.21)	12 (.47)	47-12-611-14				47-12-631-14	47-12-651-10	47-12-671-10	47-12-691-10									
4.8 (.190)	3.7 (.15)	10.4 (.41)				47-10-612-14	47-10-632-14	47-10-652-10	47-10-672-10		47-10-692-10							
5.3 (.21)	12 (.47)	47-11-610-14				47-11-632-14	47-11-652-10	47-11-672-10	47-11-692-10									

Part numbers in shaded rows (shown in table) are fully retracting in minimum panel thickness



To add a black powder coated finish, change the part number from the table as shown:

- Change 1 to 5: 47-80-102-14
- 47-80-102-54
- Change 2 to 6: 47-80-102-24
- 47-80-102-64



For a smooth knob, change the part number from the table as shown:

- Change 0 to 1: 47-90-161-20
- 47-90-161-21
- Change 4 to 5: 47-90-101-24
- 47-90-101-25

Part Number

See table

All screw part numbers shown in table are for a natural knob finish and a knurled knob

For black finish and smooth knob options, minimums may apply



4C Captive Screws

Prism series · M3, M4 and M5 thread size

- Designate access points with color
- Color match captive screws to your industrial design
- High strength screw for use with high torque drivers
- Knurled and smooth knobs available

Material and Finish

Knob: Plastic

Screw: Hardened carbon steel, zinc plate, chromate, plus sealer

Spring: 300 series stainless steel, passivated

Standoff:

Press-in: Carbon steel, zinc plate, chromate, plus sealer

PCB: Stainless steel

Flare-in and Floating:

Aluminum, natural

Performance Details

Flammability Rating: UL94-V0

Installation Notes

See pages 546-547, 627

See page 558 for details on ATCA compliant captive screws.



To ensure you receive **SOUTHCO®** quality parts, look for the segmented circle.

Recess Styles

M3

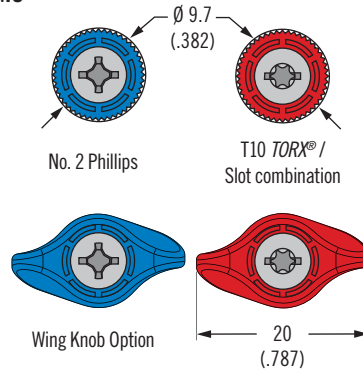

M4 and M5

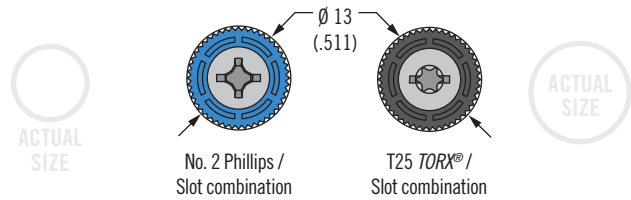

Installation Styles

M3

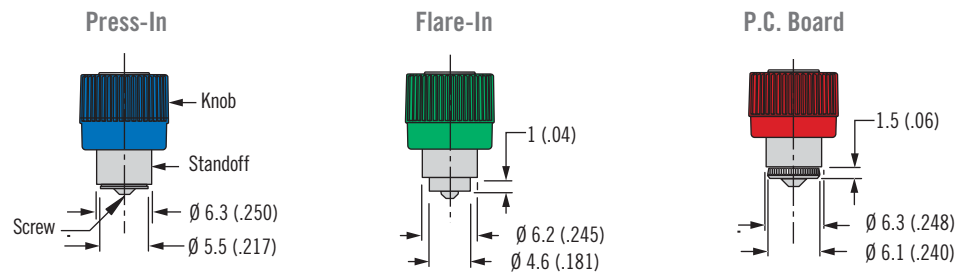

M4 and M5

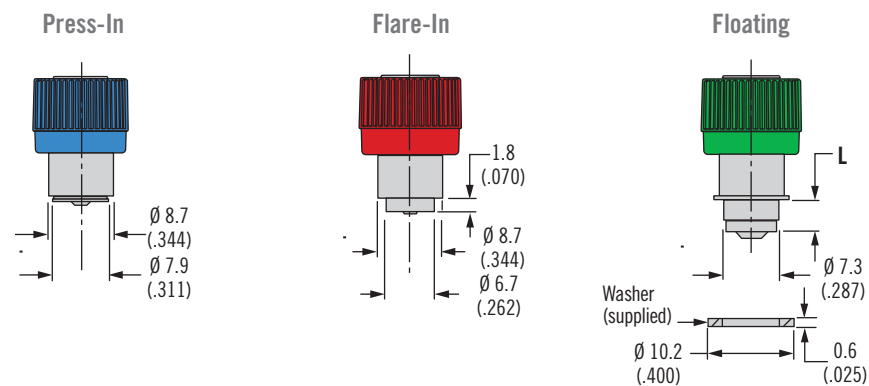

Knob Height and Screw Projection

(Press-in style shown)

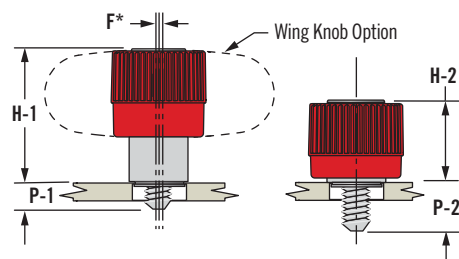

TORX® is a registered trademark of CAMCAR Innovations

Dimensions in millimeters (inch) unless otherwise stated

M3 Thread Size

Installation Style	Outer Panel Dimensions		B	Part Number		Screw Projection Beyond Outer Surface of Panel		Knob Height†		Total Float	Panel Preparation	
	A Min.	A Max.		Phillips Recess	TORX® / Slot Combination	P-1	P-2	H-1	H-2		F*	∅ D
Press-In Style	0.9 (.036)	~	~	4C-PH-M3-1P0-K000	4C-TS-M3-1P0-K000	0.8 (.03)	3.7 (.15)	11.5 (.45)	8.6 (.34)	0.7 (.03)	5.6 ^{+0.04} _{-0.04} (.219 ^{+0.02} _{-0.02})	3.2 ^{+0.2} _{-0.1} (.125 ^{+0.08} _{-0.04})
				4C-PH-M3-2P0-K000	4C-TS-M3-2P0-K000	2.5 (.10)	5.4 (.21)					
	0.8 (.031)	1.2 (.047)	~	4C-P1-P-0637-K000	4C-B1-P-0637-K000	0.6 (.024)	3.7 (.15)	12.7 (.50)	9.6 (.38)		5.6 ^{+0.08} _{-0.0} (.219 ^{+0.03} _{-0.0})	3.2 ^{+0.2} _{-0.1} (.125 ^{+0.08} _{-0.04})
				4C-P1-P-0647-K000	4C-B1-P-0647-K000		4.7 (.19)	15.1 (.59)	11 (.43)			
				4C-P1-P-0657-K000	4C-B1-P-0657-K000		5.7 (.22)	16.1 (.63)				
				4C-PH-M3-1B0-K000	4C-TS-M3-1B0-K000		1.5 (.06)	3.8 (.15)				
Flare-In Style	0.8 (.031)	1.5 (.058)	0.4 (.016)	4C-PH-M3-1F1-K000	4C-TS-M3-1F1-K000	0.8 (.03)	3.7 (.15)	11.5 (.45)	8.6 (.34)	0.7 (.03)	4.8 ^{+0.08} _{-0.05} (.189 ^{+0.03} _{-0.02})	3.0 ^{+0.2} _{-0.1} (.125 ^{+0.08} _{-0.04})
				4C-PH-M3-2F1-K000	4C-TS-M3-2F1-K000	2.5 (.10)	5.4 (.21)					
	1.2 (.047)	0.2 (.008)	4C-P1-F-0637-K000	4C-B1-F-0637-K000	0.6 (.024)	3.7 (.15)	12.7 (.50)	9.6 (.38)	11 (.43)			
			4C-P1-F-0647-K000	4C-B1-F-0647-K000		4.7 (.19)	15.1 (.59)					
			4C-P1-F-0657-K000	4C-B1-F-0657-K000		5.7 (.22)	16.1 (.63)					

(shown in table)



000
Black



008
Blue



013
Red



014
Green



Your Color
Contact Southco

Part Number

See table

Specify Wing Knob:

(M3, Press-in, Flare-in only)

To indicate Wing Knob option, change K to W of the part number

Example:

4C-PH-M3-1P0-K000, Round Knob

4C-PH-M3-1P0-W000, Wing Knob

Notes: *F indicates the maximum float in the unfastened position.

† For panels thinner than 0.9 (.036), contact Southco.

TORX® is a registered trademark of CAMCAR Innovations

Part Number

See table

To indicate color, change the last three digits of the part number. For knob style, K = knurled and N = smooth. For smooth knob change K to N. Example:

4C-PS-06-1P0-K000, black, knurled

4C-PS-06-1P0-N013, red, smooth

M4 Thread Size

Installation Style	Outer Panel Dimensions		B	L	Part Number		Screw Projection Beyond Outer Surface Of Panel		Knob Height†		Total Float	Panel Preparation	
	A Min.	A Max.			Phillips / Slot Combination	TORX® / Slot Combination	P-1	P-2	H-1	H-2		F*	∅ D
Press-In Style	0.9 (.036)v	~	~	~	4C-PS-M4-1P0-K000	4C-TS-M4-1P0-K000	0.5 (.02)	5.6 (.22)	16.3 (.64)	11.3 (.45)	0.7 (.03)	8 ⁺⁰ _{-0.08} (.315 ⁺⁰ _{-.003})	4.4 ^{+0.2} _{-0.1} (.173 ^{+0.008} _{-.004})
					4C-PS-M4-2P0-K000	4C-TS-M4-2P0-K000	2 (.08)	7.1 (.28)					
Flare-In Style	1.5 (.060)	3.2 (.058)	0.4 (.016)	~	4C-PS-M4-1F1-K000	4C-TS-M4-1F1-K000	0.6 (.02)	5.6 (.22)	16.3 (.64)	11.3 (.45)	0.6 (.02)	6.8 ^{+0.08} _{-0.04} (.266 ^{+0.005} _{-.0})	4.2 ^{+0.05} ₋₀ (.165 ^{+0.002} _{-.0})
					4C-PS-M4-2F1-K000	4C-TS-M4-2F1-K000	2.1 (.08)	7.1 (.28)					
Floating Style	0.8 (.031)	1.6 (.063)	3.1 (.122)	4 (.158)	4C-PS-M4-3T2-K000	4C-TS-M4-3T2-K000	3.8 (.15)	8.8 (.35)	16.2 (.64)	11.2 (.44)	2.3 (.09)	8.8 ^{+0.08} _{-0.03} (.346 ^{+0.003} _{-.001})	~
					4C-PS-M4-4T2-K000	4C-TS-M4-4T2-K000	5.4 (.21)	10.4 (.41)					
	1.6 (.063)	2.4 (.094)	3.9 (.153)	4.8 (.190)	4C-PS-M4-3T3-K000	4C-TS-M4-3T3-K000	3.8 (.15)	8.8 (.35)					
					4C-PS-M4-4T3-K000	4C-TS-M4-4T3-K000	5.4 (.21)	10.4 (.41)					

M5 Thread Size

Installation Style	Outer Panel Dimensions		B	L	Part Number		Screw Projection Beyond Outer Surface of Panel		Knob Height†		Total Float	Panel Preparation	
	A Min.	A Max.			Phillips / Slot Combination	TORX® / Slot Combination	P-1	P-2	H-1	H-2		F*	∅ D
Press-In Style	0.9 (.036)†	~	~	~	4C-PS-M5-1P0-K000	4C-TS-M5-1P0-K000	0.4 (.2)	5.6 (.22)	16.4 (.65)	11.3 (.45)	0.8 (.03)	8 ⁺⁰ _{-0.08} (.315 ⁺⁰ _{-.003})	5.2 ^{+0.2} _{-0.1} (.205 ^{+0.008} _{-.004})
					4C-PS-M5-2P0-K000	4C-TS-M5-2P0-K000	2 (.08)	7.2 (.28)					
Flare-In Style	1.5 (.06)	3.2 (.058)	0.4 (.016)	~	4C-PS-M5-1F1-K000	4C-TS-M5-1F1-K000	0.5 (.02)	5.6 (.22)	16.4 (.65)	11.3 (.45)	0.7 (.03)	6.8 ^{+0.08} _{-0.04} (.266 ^{+0.005} _{-.0})	4.9 ^{+0.05} ₋₀ (.191 ^{+0.002} _{-.0})
					4C-PS-M5-2F1-K000	4C-TS-M5-2F1-K000	2.1 (.08)	7.2 (.28)					
Floating Style	0.8 (.031)	1.6 (.063)	3.1 (.122)	4 (.158)	4C-PS-M5-3T2-K000	4C-TS-M5-3T2-K000	3.7 (.15)	8.9 (.35)	16.3 (.64)	11.2 (.44)	2.3 (.09)	8.8 ^{+0.08} _{-0.03} (.346 ^{+0.003} _{-.001})	~
					4C-PS-M5-4T2-K000	4C-TS-M5-4T2-K000	5.3 (.21)	10.5 (.41)					

Part Number

See table

To indicate color, change the last three digits of the part number. For knob style, K = knurled and N = smooth. For smooth knob change K to N. Example:

4C-PS-06-1P0-K000, black, knurled
4C-PS-06-1P0-N013, red, smooth

Part Number

See table

Specify Wing Knob:

(M3, Press-in, Flare-in only)

To indicate Wing Knob option, change K to W of the part number

Example:

4C-PH-M3-1P0-K000, Round Knob

4C-PH-M3-1P0-W000, Wing Knob

Notes: *F indicates the maximum float in the unfastened position.

† For panels thinner than 0.9 (.036), contact Southco.

TORX® is a registered trademark of CAMCAR Innovations



000
Black



008
Blue



013
Red



014
Green



Your Color
Contact Southco

4C Captive Screws

Prism series · 4-40, 6-32 and 10-32 thread size



Recess Styles

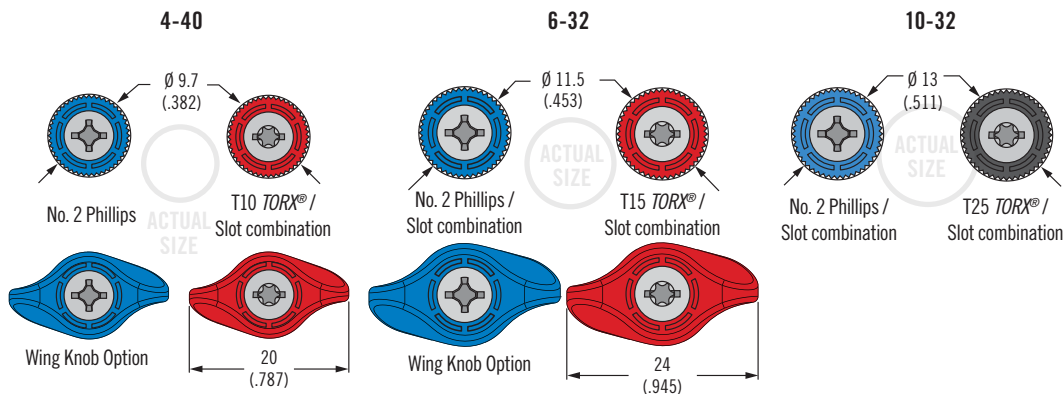

Installation Styles

4-40

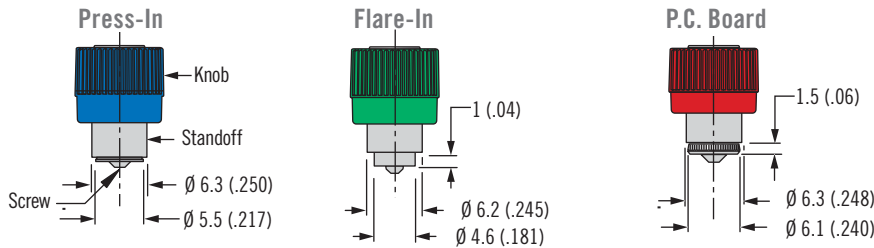

6-32

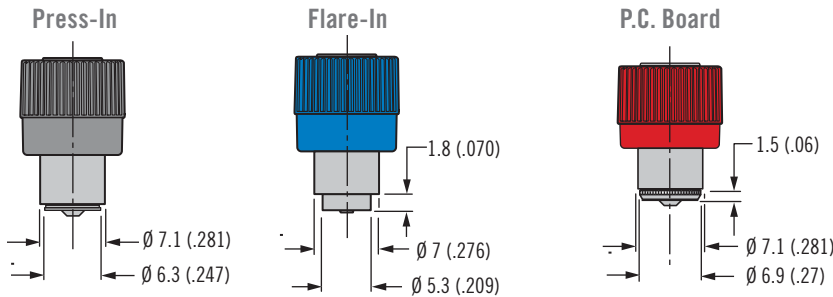

10-32

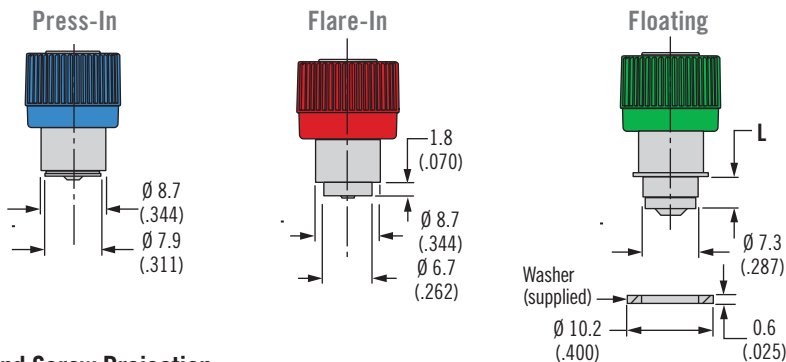

Knob Height and Screw Projection

(Press-in style shown)

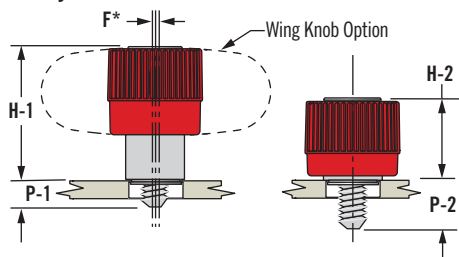

- Designate access points with color
- Color match captive screws to your industrial design
- High strength screw for use with high torque drivers
- Knurled, smooth and wing knobs available

Material and Finish

Knob: Plastic

Screw: Hardened carbon steel, zinc plate, chromate, plus sealer

Spring: 300 series stainless steel, passivated

Standoff:

Press-in: Carbon steel, zinc plate, chromate, plus sealer

PCB: Stainless steel

Flare-in and Floating: Aluminum, natural

Performance Details

Flammability Rating: UL94-V0

Installation Notes

See pages 546-547, 627

 To ensure you receive SOUTHCO® quality parts, look for the segmented circle.

TORX® is a registered trademark of CAMCAR Innovations

4-40 Thread Size

Installation Style	Outer Panel Dimensions		B	Part Number		Screw Projection Beyond Outer Surface of Panel		Knob Height†		Total Float	Panel Preparation	
	A Min.	A Max.		Phillips Recess	TORX® / Slot Combination	P-1	P-2	H-1	H-2		F*	∅ D
Press-In Style	0.9† (.036)	~	~	4C-PH-04-1P0-K000	4C-TS-04-1P0-K000	0.8 (.03)	3.8 (.15)	11.5 (.45)	8.6 (.34)	0.7 (.03)	5.6 ^{+0.04} _{-0.04} (.219 ^{+0.003} ₋₀)	3.2 ^{+0.2} _{-0.1} (.125 ^{+0.008} _{-0.004})
				4C-PH-04-2P0-K000	4C-TS-04-2P0-K000	2.5 (.10)	5.3 (.21)					
P.C. Board Style	1.6 (.063)	~	~	4C-PH-04-1B0-K000	4C-TS-04-1B0-K000	1.5 (.06)	3.8 (.15)	10.9 (.43)	8.5 (.33)	0.7 (.03)	5.6 ^{+0.1} _{-0.05} (.219 ^{+0.004} _{-0.002})	3.2 ^{+0.2} _{-0.1} (.125 ^{+0.008} _{-0.004})
				4C-PH-04-2B0-K000	4C-TS-04-2B0-K000	3.3 (.13)	5.5 (.22)					
Flare-In Style	0.8 (.031)	1.5 (.059)	0.4 (.016)	4C-PH-04-1F1-K000	4C-TS-04-1F1-K000	0.8 (.03)	3.7 (.15)	11.5 (.45)	8.6 (.34)	0.7 (.03)	4.8 ^{+0.08} _{-0.05} (.187 ^{+0.005} _{-0.000})	3.0 ^{+0.2} _{-0.1} (.125 ^{+0.008} _{-0.004})
				4C-PH-04-2F1-K000	4C-TS-04-2F1-K000	2.5 (.10)	5.4 (.21)					

Part Number

See table

To indicate color, change the last three digits of the part number.

For knob style, K = knurled and N = smooth. For smooth knob change K to N. Example:

4C-PS-06-1P0-K000, black, knurled
4C-PS-06-1P0-N013, red, smooth



000
Black



008
Blue



013
Red



014
Green



Your Color
Contact Southco

Part Number

See table

Specify Wing Knob:

(4-40 and 6-32, Press-in and Flare-in only)

To indicate Wing Knob option, change K to W of the part number

Example:

4C-PS-06-1P0-K000, Round Knob

4C-PS-06-1P0-W000, Wing Knob

Notes: *F indicates the maximum float in the unfastened position.
† For panels thinner than 0.9 (.036), contact Southco.

TORX® is a registered trademark of CAMCAR Innovations

6-32 Thread Size

Installation Style	Outer Panel Dimensions		B	Part Number		Screw Projection Beyond Outer Surface of Panel		Knob Height†		Total Float	Panel Preparation	
	A Min.	A Max.		Phillips / Slot Combination	TORX® / Slot Combination	P-1	P-2	H-1	H-2		F*	∅ D
Press-In Style	0.9† (.036)	~	~	4C-PS-06-1P0-K000	4C-TS-06-1P0-K000	0.7 (.03)	5 (.20)	15.5 (.61)	11.3 (.44)	0.7 (.03)	6.4 ^{+0.03} _{-0.05} (.250 ^{+0.01} _{-0.02})	3.7 ^{+0.2} _{-0.1} (.146 ^{+0.08} _{-0.04})
				4C-PS-06-2P0-K000	4C-TS-06-2P0-K000	2.3 (.09)	6.6 (.26)				5.8 ^{+0.08} _{-0.00} (.228 ^{+0.03} _{-0.00})	3.7 ^{+0.2} _{-0.1} (.146 ^{+0.08} _{-0.04})
	0.8 (.031)	1.6 (.063)	~	4C-AB-P-0740-K000	4C-BB-P-0740-K000	0.7 (.03)	4 (.16)	14.6 (.57)				
				4C-AB-P-0750-K000	4C-BB-P-0750-K000		5 (.20)	15.6 (.61)				
				4C-AB-P-0760-K000	4C-BB-P-0760-K000		6 (.24)	16.6 (.65)				
				4C-AB-P-0770-K000	4C-BB-P-0770-K000		7 (.28)	17.6 (.69)				
				4C-AB-P-0740-W000	4C-BB-P-0740-W000		4 (.16)	14.6 (.57)				
4C-AB-P-0750-W000	4C-BB-P-0750-W000	5 (.20)	15.6 (.61)									
P.C. Board Style	1.5 (.06)	~	~	4C-PS-06-1B0-K000	4C-TS-06-1B0-K000	1.7 (.07)	6.2 (.25)	14.5 (.57)	10 (.39)	6.4 ± 0.1 (.252 ± .004)	3.7 ^{+0.2} _{-0.1} (.146 ^{+0.08} _{-0.04})	
Flare-In Style	1.5 (.059)	3.2 (.125)	0.4 (.016)	4C-PS-06-1F1-K000	4C-TS-06-1F1-K000	0.8 (.03)	5 (.20)	15.5 (.61)	11.3 (.44)	0.7 (.03)	5.4 ^{+0.1} _{-0.0} (.213 ^{+0.05} _{-0.00})	3.7 ^{+0.2} _{-0.1} (.146 ^{+0.08} _{-0.04})
				4C-PS-06-2F1-K000	4C-TS-06-2F1-K000	2.3 (.09)	6.6 (.26)					
	0.8 (.031)	1.6 (.063)	0.2 (.008)	4C-AB-F-0740-K000	4C-BB-F-0740-K001	0.7 (.03)	4 (.16)	14.6 (.57)				
				4C-AB-F-0750-K000	4C-BB-F-0750-K000		5 (.20)	15.6 (.61)				
				4C-AB-F-0760-K000	4C-BB-F-0760-K000		6 (.24)	16.6 (.65)				
				4C-AB-F-0770-K000	4C-BB-F-0770-K000		7 (.28)	17.6 (.69)				
				4C-AB-F-0740-W000	4C-BB-F-0740-W000		4 (.16)	14.6 (.57)				
4C-AB-F-0750-W000	4C-BB-F-0750-W000	5 (.20)	15.6 (.61)									

10-32 Thread Size

Installation Style	Outer Panel Dimensions		B	L	Part Number		Screw Projection Beyond Outer Surface of Panel		Knob Height†		Total Float	Panel Preparation	
	A Min.	A Max.			Phillips / Slot Combination	TORX® / Slot Combination	P-1	P-2	H-1	H-2		F*	∅ D
Press-In Style	0.9† (.036)	~	~	~	4C-PS-10-1P0-K000	4C-TS-10-1P0-K000	0.5 (.02)	5.6 (.22)	11.3 (.45)	0.6 (.02)	8 ⁺⁰ _{-0.08} (.315 ⁺⁰ _{-0.03})	5.2 ^{+0.2} _{-0.1} (.205 ^{+0.08} _{-0.04})	
					4C-PS-10-2P0-K000	4C-TS-10-2P0-K000	2 (.08)	7.1 (.28)					
Flare-In Style	1.5 (.058)	3.2 (.125)	0.4 (.016)	1.8 (.070)	4C-PS-10-1F1-K000	4C-TS-10-1F1-K000	0.6 (.02)	5.6 (.22)	16.3 (.64)	0.6 (.02)	6.8 ^{+0.08} _{-0.04} (.266 ^{+0.05} ₋₀)	4.9 ^{+0.05} ₋₀ (.191 ^{+0.02} ₋₀)	
					4C-PS-10-2F1-K000	4C-TS-10-2F1-K000	2.1 (.08)	7.1 (.28)					
Floating Style	0.8 (.031)	1.6 (.063)	3.1 (.122)	4 (.158)	4C-PS-10-3T2-K000	4C-TS-10-3T2-K000	3.8 (.15)	8.8 (.35)	11.2 (.44)	2.3 (.09)	8.8 ^{+0.08} _{-0.03} (.346 ^{+0.09} _{-0.01})	~	
	1.6 (.063)	2.4 (.094)	3.9 (.153)	4.8 (.190)	4C-PS-10-4T2-K000	4C-TS-10-4T2-K000	5.4 (.21)	10.4 (.41)					
					4C-PS-10-3T3-K000	4C-TS-10-3T3-K000	3.8 (.15)	8.8 (.35)					
					4C-PS-10-4T3-K000	4C-TS-10-4T3-K000	5.4 (.21)	10.4 (.41)					

(shown in table)



000
Black



008
Blue



013
Red



014
Green



Your Color
Contact Southco

Part Number

See table

Specify Wing Knob:

(4-40 and 6-32, Press-in and Flare-in only)

To indicate Wing Knob option, change K to W of the part number

Example:

4C-PS-06-1P0-K000, Round Knob

4C-PS-06-1P0-W000, Wing Knob

Notes: *F indicates the maximum float in the unfastened position.

† For panels thinner than 0.9 (.036), contact Southco.

TORX® is a registered trademark of CAMCAR Innovations



47 Captive Screws

Restricted access series · M4 and M5 thread size

- Reduces risk of unauthorized access
- Meets UL-1950, IEC 950 and EN-60950
- Hand operation to secure with tool-only removal

Material and Finish

Ferrule:

Press-in: Hardened carbon steel, zinc plate, chromate, plus sealer
 Flare-in and Floating: Aluminum, natural

Knob: Aluminum, natural or black organic coating

Screw: Hardened carbon steel, zinc plate, chromate, plus sealer

Installation Notes

See pages 546-547, 627

Recess Styles

Slotted

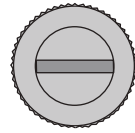

No. 2 Phillips

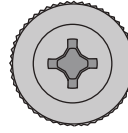

T25 TORX®

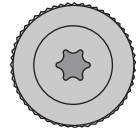

ACTUAL SIZE

Knob Height and Screw Projection

(Press-in style shown)

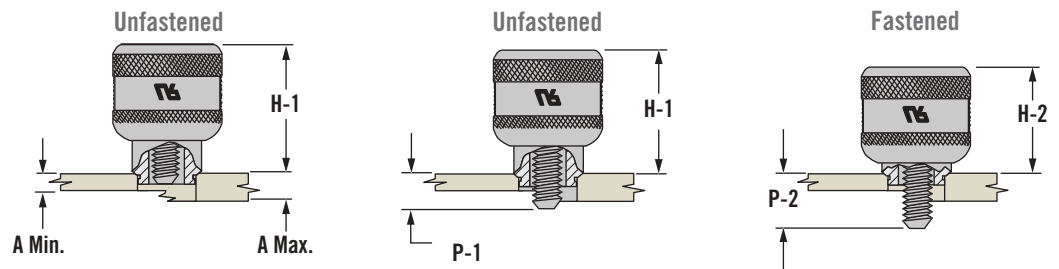

Installation Styles

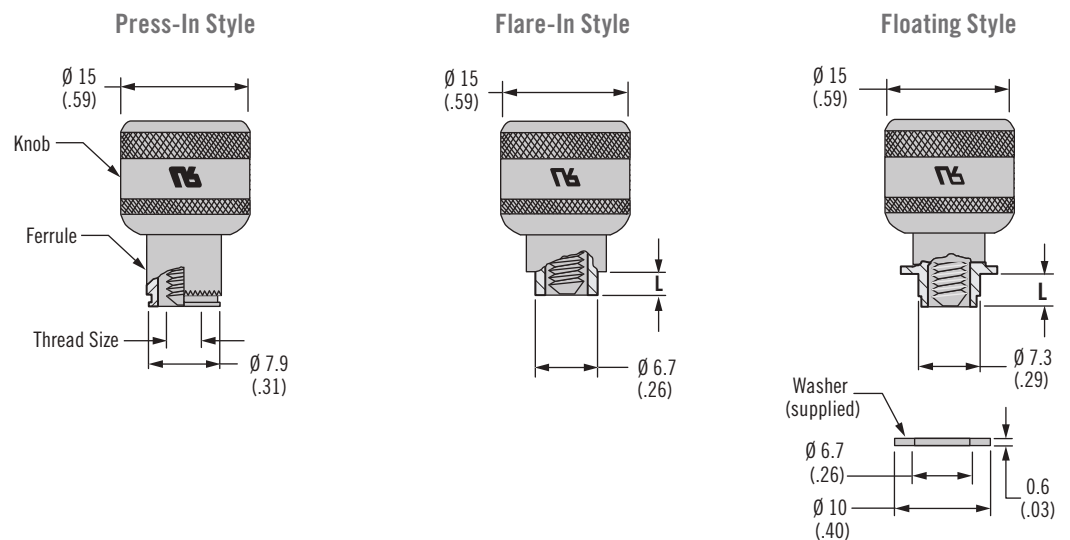

TORX® is a registered trademark of CAMCAR Innovations

M4 Thread Size

Installation Style	Knob Height		Outer Panel Dimensions		Dimension B*	Flange Length L	Screw Projection Beyond Outer Surface of Panel		Part Number		
	H-1	H-2	A Min.	A Max.			P-1	P-2	Slotted Recess	Phillips Recess	TORX® Recess
Press-In Style	18.5 (.73)	14 (.55)	0.9 (.036)	~	~	~	0.7 (.03)	5.6 (.22)	47-90-301-22	47-90-321-22	47-90-341-22
							2.3 (.09)	7.2 (.28)	47-91-301-22	47-91-321-22	47-91-341-22
							3.8 (.15)	8.7 (.34)	47-92-301-22	47-92-321-22	47-92-341-22
							5.4 (.21)	10.3 (.41)	47-93-301-22	47-93-321-22	47-93-341-22
Flare-In Style	18 (.70)	13 (.51)	1.5 (.058)	3.2 (.125)	0.6 (.023)	1.8 (.07)	1.4 (.06)	6.2 (.24)	47-80-302-22	47-80-322-22	47-80-342-22
			3.2 (.125)	4.8 (.188)	1.6 (.062)	3.4 (.14)	3.1 (.12)	7.9 (.31)	47-80-304-22	47-80-324-22	47-80-344-22
			1.5 (.058)	3.2 (.125)	0.6 (.023)	1.8 (.07)	3.1 (.12)	7.9 (.31)	47-81-302-22	47-81-322-22	47-81-342-22
							4.1 (.16)	8.9 (.35)	47-82-302-22	47-82-322-22	47-82-342-22
							6.1 (.24)	10.9 (.43)	47-83-302-22	47-83-322-22	47-83-342-22
							2.4 (.09)	7.2 (.28)	47-80-310-22	47-80-330-22	47-80-350-22
Floating Style	18 (.70)	14 (.55)	0.1 (.001)	0.8 (.031)	2.3 (.09)	3.2 (.13)	3.4 (.13)	8.2 (.32)	47-81-310-22	47-81-330-22	47-81-350-22
							5.4 (.21)	10.2 (.40)	47-82-310-22	47-82-330-22	47-82-350-22
							2.4 (.09)	7.2 (.22)	47-80-311-22	47-80-331-22	47-80-351-22
			0.8 (.031)	1.6 (.063)	3.1 (.12)	4 (.16)	3.4 (.13)	8.2 (.32)	47-81-311-22	47-81-331-22	47-81-351-22
							5.4 (.21)	10.2 (.40)	47-82-311-22	47-82-331-22	47-82-351-22
							2.4 (.09)	7.2 (.22)	47-80-311-22	47-80-331-22	47-80-351-22

M5 Thread Size

Press-In Style	18.5 (.73)	14 (.55)	0.9 (.036)	~	~	~	0.7 (.03)	5.6 (.22)	47-90-501-22	47-90-521-22	47-90-541-22
							2.3 (.09)	7.2 (.28)	47-91-501-22	47-91-521-22	47-91-541-22
							3.8 (.15)	8.7 (.34)	47-92-501-22	47-92-521-22	47-92-541-22
							5.4 (.21)	10.3 (.41)	47-93-501-22	47-93-521-22	47-93-541-22
Flare-In Style	18 (.70)	13 (.51)	1.5 (.058)	3.2 (.125)	0.6 (.023)	1.8 (.07)	1.4 (.06)	6.2 (.24)	47-80-502-22	47-80-522-22	47-80-542-22
			3.2 (.125)	4.8 (.188)	1.6 (.062)	3.4 (.14)	3.1 (.12)	7.9 (.31)	47-80-504-22	47-80-524-22	47-80-544-22
			1.5 (.058)	3.2 (.125)	0.6 (.023)	1.8 (.07)	3.1 (.12)	7.9 (.31)	47-81-502-22	47-81-522-22	47-81-542-22
							4.1 (.16)	8.9 (.35)	47-82-502-22	47-82-522-22	47-82-542-22
							6.1 (.24)	10.9 (.43)	47-83-502-22	47-83-522-22	47-83-542-22
							4.1 (.16)	8.9 (.35)	47-81-504-22	47-81-524-22	47-81-544-22
Floating Style	18 (.70)	14 (.55)	0.1 (.001)	0.8 (.031)	2.3 (.09)	3.2 (.13)	2.4 (.09)	7.2 (.28)	47-80-510-22	47-80-530-22	47-80-550-22
							3.4 (.13)	8.2 (.32)	47-81-510-22	47-81-530-22	47-81-550-22
							5.4 (.21)	10.2 (.40)	47-82-510-22	47-82-530-22	47-82-550-22
			0.8 (.031)	1.6 (.063)	3.1 (.12)	4 (.16)	2.4 (.09)	7.2 (.28)	47-80-511-22	47-80-531-22	47-80-551-22
							3.4 (.13)	8.2 (.32)	47-81-511-22	47-81-531-22	47-81-551-22
							5.4 (.21)	10.4 (.40)	47-82-511-22	47-82-531-22	47-82-551-22
1.6 (.063)	2.4 (.094)	3.9 (.15)	4.8 (.19)	3.4 (.15)	8.2 (.35)	47-80-512-22	47-80-532-22	47-80-552-22			
				5.4 (.21)	10.2 (.40)	47-81-512-22	47-81-532-22	47-81-552-22			

Part numbers in shaded rows (shown in table) are fully retracting in minimum panel thickness



To add a black finish, change the part number from the table as shown:

Change 2 to 6: 47-80-102-22
 47-80-102-62

TORX® is a registered trademark of CAMCAR Innovations

Dimensions in millimeters (inch) unless otherwise stated

Part Number

See table

All screw part numbers shown in table are for a natural finish

For black finish minimums may apply



47 Captive Screws

Restricted access series · 6-32 and 10-32 thread size

- Reduces risk of unauthorized access
- Meets UL-1950, IEC 950 and EN-60950
- Hand operation to secure with tool-only removal

Material and Finish

Ferrule:

Press-in: Hardened carbon steel, zinc plate, chromate, plus sealer
Flare-in and Floating: Aluminum, natural

Knob: Aluminum, natural or black organic coating

Screw: Hardened carbon steel, zinc plate, chromate, plus sealer

Installation Notes

See pages 546-547, 627

Recess Styles

Slotted

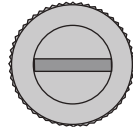

No. 2 Phillips

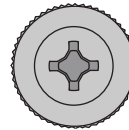

T15 TORX® - 6-32
T25 TORX® - 10-32

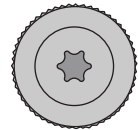

ACTUAL
SIZE

Knob Height and Screw Projection

(Press-in style shown)

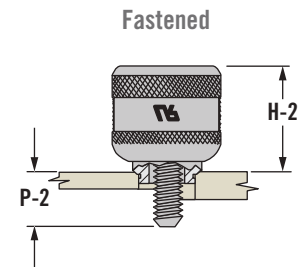
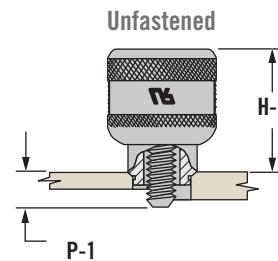
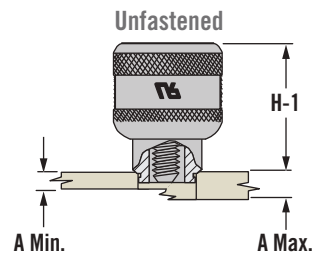

Installation Styles

Press-In Style

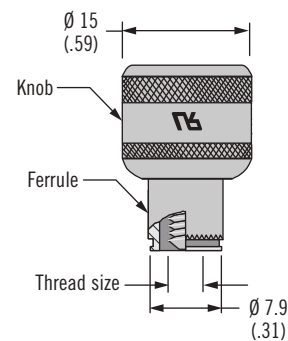

Flare-In Style

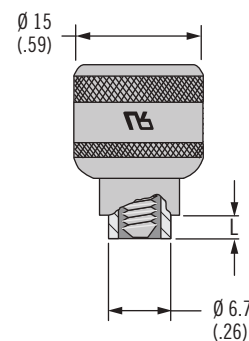

Floating Style

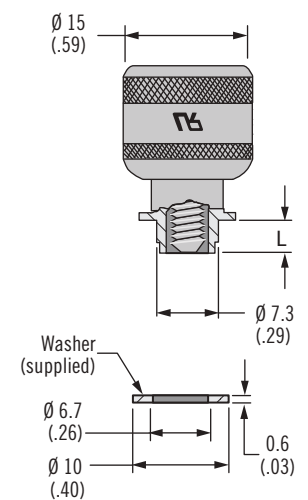

TORX® is a registered trademark of CAMCAR Innovations

Dimensions in millimeters (inch) unless otherwise stated

6-32 Thread Size

Installation Style	Knob Height†		Outer Panel Dimensions		Dimension B*	Flange Length L	Screw Projection Beyond Outer Surface Of Panel		Part Number		
	H-1	H-2	A Min.	A Max.			P-1	P-2	Slotted Recess	Phillips Recess	TORX® Recess
Press-In Style	18.5 (.73)	14 (.54)	0.9 (.036)	~	~	~	0.5 (.02)	5.3 (.21)	47-60-201-22	47-60-221-22	47-60-241-22
							2.3 (.09)	6.9 (.27)	47-61-201-22	47-61-221-22	47-61-241-22
							3.8 (.15)	8.3 (.33)	47-62-201-22	47-62-221-22	47-62-241-22
							5.3 (.21)	10.1 (.41)	47-63-201-22	47-63-221-22	47-63-241-22
Flare-In Style	18 (.70)	13 (.51)	1.5 (.058)	3.2 (.125)	0.6 (.023)	1.8 (.07)	1.4 (.06)	6.2 (.24)	47-10-202-22	47-10-222-22	47-10-242-22
			3.2 (.125)	4.8 (.189)	1.6 (.062)	3.4 (.14)	3.1 (.12)	7.9 (.31)	47-10-204-22	47-10-224-22	47-10-244-22
			1.5 (.058)	3.2 (.125)	0.6 (.023)	1.8 (.07)	3.1 (.12)	7.9 (.31)	47-11-202-22	47-11-222-22	47-11-242-22
			4.1 (.16)	8.9 (.35)	47-12-202-22	47-12-222-22	47-12-242-22				
			6.1 (.24)	10.9 (.43)	47-13-202-22	47-13-222-22	47-13-242-22				
			3.2 (.125)	4.8 (.189)	1.6 (.062)	3.4 (.14)	4.1 (.16)	8.9 (.35)	47-11-204-22	47-11-224-22	47-11-244-22
			6.1 (.24)	10.9 (.43)	47-12-204-22	47-12-224-22	47-12-244-22				
			4.1 (.16)	8.9 (.35)	47-11-204-22	47-11-224-22	47-11-244-22				
Floating Style	18 (.70)	14 (.54)	0.1 (.001)	0.8 (.031)	2.3 (.09)	3.2 (.13)	2.4 (.09)	7.2 (.28)	47-10-210-22	47-10-230-22	47-10-250-22
							3.4 (.13)	8.2 (.32)	47-11-210-22	47-11-230-22	47-11-250-22
							5.4 (.21)	10.2 (.40)	47-12-210-22	47-12-230-22	47-12-250-22
			0.8 (.031)	1.6 (.063)	3.1 (.12)	4 (.16)	2.4 (.09)	7.2 (.22)	47-10-211-22	47-10-231-22	47-10-251-22
							3.4 (.13)	8.2 (.32)	47-11-211-22	47-11-231-22	47-11-251-22
							5.4 (.21)	10.2 (.40)	47-12-211-22	47-12-231-22	47-12-251-22
			1.6 (.063)	2.4 (.094)	3.9 (.15)	4.8 (.19)	3.4 (.13)	8.2 (.32)	47-10-212-22	47-10-232-22	47-10-252-22
							5.4 (.21)	10.2 (.40)	47-11-212-22	47-11-232-22	47-11-252-22

10-32 Thread Size

Press-In Style	18.5 (.73)	14 (.54)	0.9 (.036)	~	~	~	0.7 (.03)	5.6 (.22)	47-60-501-22	47-60-521-22	47-60-541-22
							2.3 (.09)	7.2 (.28)	47-61-501-22	47-61-521-22	47-61-541-22
							3.8 (.15)	8.7 (.34)	47-62-501-22	47-62-521-22	47-62-541-22
							5.4 (.21)	10.3 (.41)	47-63-501-22	47-63-521-22	47-63-541-22
Flare-In Style	18 (.70)	13 (.51)	1.5 (.058)	3.2 (.125)	0.6 (.023)	1.8 (.07)	1.4 (.06)	6.2 (.24)	47-10-502-22	47-10-522-22	47-10-542-22
			3.2 (.125)	4.8 (.189)	1.6 (.062)	3.4 (.14)	3.1 (.12)	7.9 (.31)	47-10-504-22	47-10-524-22	47-10-544-22
			1.5 (.058)	3.2 (.125)	0.6 (.023)	1.8 (.07)	3.1 (.12)	7.9 (.31)	47-11-502-22	47-11-522-22	47-11-542-22
			4.1 (.16)	8.9 (.35)	47-12-502-22	47-12-522-22	47-12-542-22				
			6.1 (.24)	10.9 (.43)	47-13-502-22	47-13-522-22	47-13-542-22				
			3.2 (.125)	4.8 (.189)	1.6 (.062)	3.2 (.14)	4.1 (.16)	8.9 (.35)	47-11-504-22	47-11-524-22	47-11-544-22
			6.1 (.24)	10.9 (.43)	47-12-504-22	47-12-524-22	47-12-544-22				
			4.1 (.16)	8.9 (.35)	47-11-504-22	47-11-524-22	47-11-544-22				
Floating Style	18 (.70)	14 (.54)	0.1 (.001)	0.8 (.031)	2.3 (.09)	3.2 (.13)	2.4 (.09)	7.2 (.28)	47-10-510-22	47-10-530-22	47-10-550-22
							3.4 (.13)	8.2 (.32)	47-11-510-22	47-11-530-22	47-11-550-22
							5.4 (.21)	10.2 (.40)	47-12-510-22	47-12-530-22	47-12-550-22
			0.8 (.031)	1.6 (.063)	3.1 (.12)	4 (.16)	2.4 (.09)	7.2 (.28)	47-10-511-22	47-10-531-22	47-10-551-22
							3.4 (.13)	8.2 (.32)	47-11-511-22	47-11-531-22	47-11-551-22
							5.4 (.21)	10.2 (.40)	47-12-511-22	47-12-531-22	47-12-551-22
			1.6 (.063)	2.4 (.094)	3.9 (.15)	4.8 (.19)	3.4 (.13)	8.2 (.32)	47-10-512-22	47-10-532-22	47-10-552-22
							5.4 (.21)	10.2 (.40)	47-11-512-22	47-11-532-22	47-11-552-22

Part numbers in shaded rows (shown in table) are fully retracting in minimum panel thickness



To add a black finish, change the part number from the table as shown:

Change 2 to 6: 47-80-102-22
 47-80-102-62

Part Number

See table

All screw part numbers shown in table are for a natural finish

For black finish minimums may apply



47/4C Captive Screws

Panel preparation and installation

Installation Notes

1. Prepare panel as shown. Top edge of hole should be sharp
2. Press captive screw into panel until ferrule is installed as shown

Installation closer to the panel edge requires a fixture to constrain the panel edges

Notes

Recommended minimum distance from edge of panel to centerline of hole is $1.5 \times \phi D$

Performance Details

Pullout force: 360 N (80 lbf)
Side load against unfastened knob: 200 N (45 lbf)

Installation Notes

1. Prepare panel as shown.
2. Use pilot lead-in to guide assembly into hole and press knurl into panel until ferrule shoulder contacts surface

Notes

Strength data based on drilled holes in G-10 P.C. Board

Installation Notes

1. Prepare panel as shown.
2. Install tool in suitable press. Only LIGHT pressure will be required
3. Insert screw assembly into prepared hole in panel
4. Place work under press, center tool over screw thread and flare ferrule into counter-sink in panel. Use LIGHT pressure

Installation Force:
1600 N (350 lbf) to 2500 N (550 lbf)
Installation force depends on thread size

Press-In Style

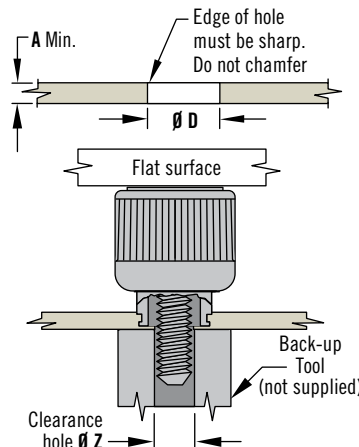

See page 627 for additional installation guidelines

Notes: (47) For use in material hardness Rb85 or less, such as low carbon steels that are half hard or softer, stainless steels in the annealed condition and aluminum. (4C/52) For use in material hardness Rb65 or less, such as low carbon steels that are quarter hard or softer, stainless steels in the annealed condition and aluminum.

Thread Size	ϕD	Clearance Hole ϕZ $\begin{matrix} +0.2 & +.008 \\ -0.1 & -.004 \end{matrix}$
M3 or 4-40	$5.6^{+0.04}_{-.003}$ (.219)	3.2 (.125)
M3.5 or 6-32	$6.4^{+0.03}_{-.005}$ (.250)	3.7 (.146)
M4 or 8-32	$8^{+0}_{-.008}$ (.315)	4.4 (.173)
M5 or 10-32	$8^{+0}_{-.008}$ (.315)	5.2 (.205)
M6 or 1/4-20	$9.5^{+0.1}_{-.003}$ (.375)	6.2 (.260)

P.C. Board Style

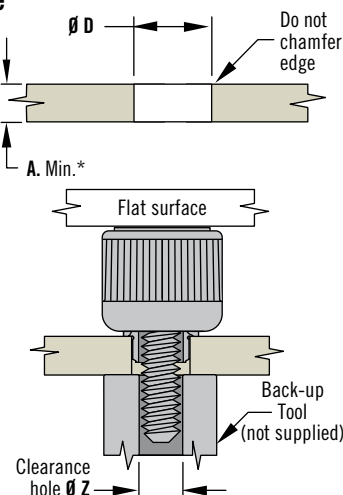

Thread Size	ϕD	Clearance Hole ϕZ $\begin{matrix} +0.2 & +.008 \\ -0.1 & -.004 \end{matrix}$
M3 or 4-40	$5.6^{+0.1}_{-.005}$ (.219)	3.2 (.125)
M3.5 or 6-32	6.4 ± 1 (.252 ± .004)	3.7 (.146)

Flare-In Style

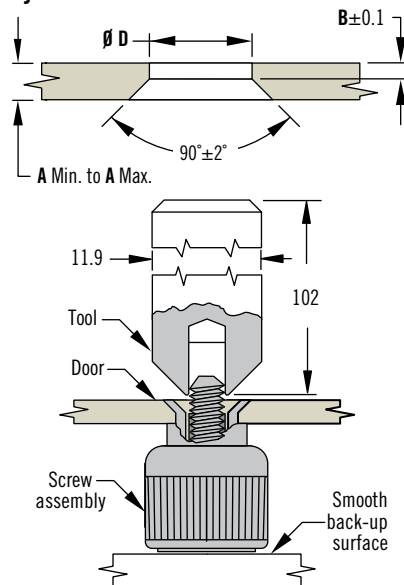

Thread Size	ϕD	Tool Part Number
M3 or 4-40	$4.8^{+0.08}_{-.005}$ (.187)	47-104
M3.5 or 6-32	$5.4^{+0.1}_{-.005}$ (.213)	47-106
M4 or 8-32	$6.8^{+0.08}_{-.004}$ (.266)	47-108
10-32	$6.8^{+0.08}_{-.004}$ (.266)	47-110
M5	$6.8^{+0.08}_{-.004}$ (.266)	47-115
M6 or 1/4-20	$8.2^{+0.1}_{-.005}$ (.323)	47-125

Floating Style

Panel preparation 1

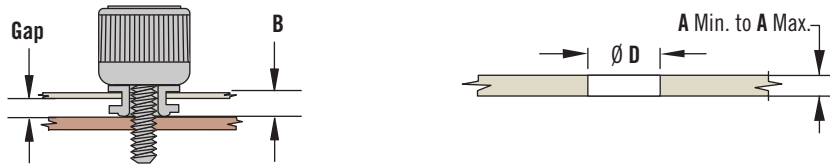

Panel preparation 2

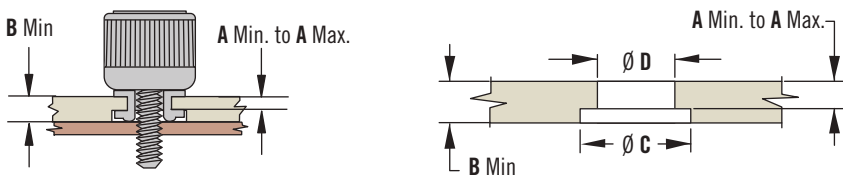

Thread Size	Tool Part Number
M3 or 4-40	47-04
M3.5 or 6-32	47-06
M4 or 8-32	47-08
M5	47-05
10-32	47-10
M6 or 1/4-20	47-25

Thread Size	Ø D	Counterbore Min. Ø C
M3 or 4-40	6.4 (.250) <small>+0.008 (+.003) -0.03 -0.001</small>	9.4 (.375)
M3.5 or 6-32	7.2 (.283)	10.5 (.413)
M4 or 8-32	8.8 (.346)	12 (.469)
M5 or 10-32	8.8 (.346)	12 (.469)
M6 or 1/4-20	10.5 (.413)	13.5 (.531)

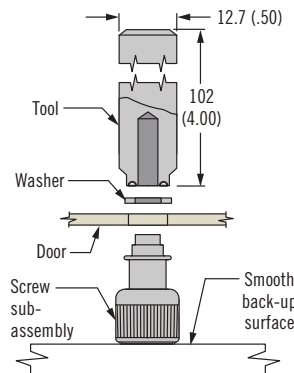

Installation Notes

Floating and Snap-in style:
Panel preparation 1:
Requires space between inner and outer panels.

Specify the fastener for panel thickness A to fall between the range A Minimum to A Maximum:
gap = B - A outer panel thickness

Panel preparation 2:
Counter bore the panel (B = Minimum panel thickness) to a thickness (A) between the range of A Minimum and A Maximum

Minimum bore depth = panel thickness - A Maximum

For gap = Ø, panel thickness must be ≥ B value (before counterbore) for the given part number

Notes

B and A Maximum values are provided in the corresponding fastener selection tables for each part number

If holes are drilled, top edge of hole should be chamfered

Snap-In Style

Panel preparation 1

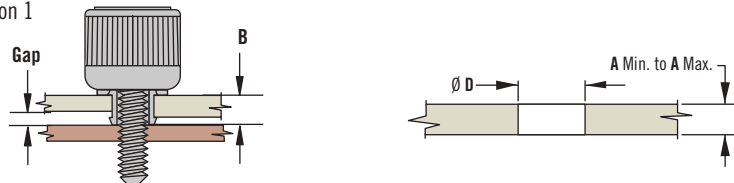

Panel preparation 2

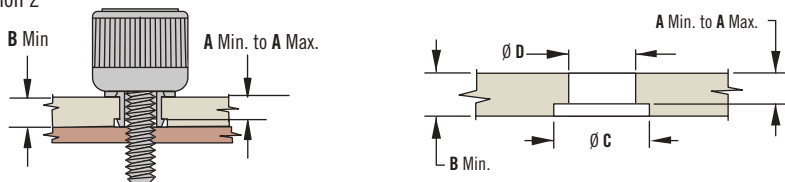

Thread Size	Ø D	Counterbore Min. Ø C
M3.5 or 6-32	6.4 (.250) <small>+0 -0.1 (± .002)</small>	7.5 (.295)
M4 or 8-32	6.4 (.250)	7.5 (.295)
M5 or 10-32	6.4 (.250)	7.5 (.295)

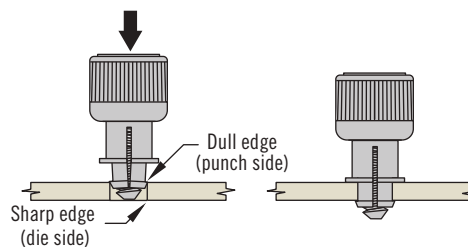

Dimensions in millimeters (inch) unless otherwise stated



47-SM Captive Screws

Styled knob series · Surface Mount Technology (SMT) Style

- For installation to PC Board material utilizing surface mount technology
- Smooth knob meets UL-1950
- Designed for hand operation
- Spring ejected
- Variety of sizes, recesses

Material and Finish

Ferrule: Steel, Tin plated

Knob:

Aluminum, natural

Screw: Hardened carbon steel, zinc plated, chromate, plus sealer

Internal spring: 300 series stainless steel passivated

Plug: Silicone rubber

Installation Notes

See page 551



To ensure you receive **SOUTHCO®** quality parts, look for the segmented circle

Part Number

See table

Recess Styles

TORX® / Slot Combination

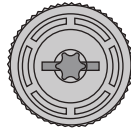

T10 TORX® / Slot Combination (M3,4-40)
T15 TORX® / Slot (6-32)

Phillips / Slot Combination

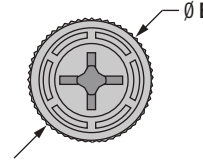

No. 1 Phillips / Slot Recess (M3,4-40)
No. 2 Phillips / Slot Recess (6-32)

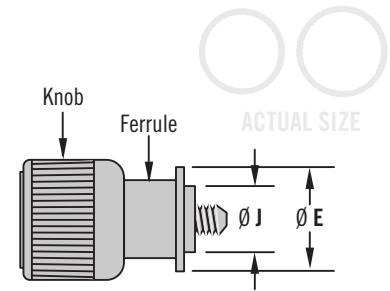

Knob Height and Screw Projection

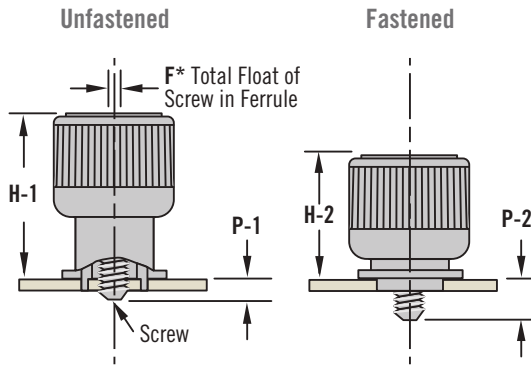

* Value represents float in unfastened position
Notes: P-1, P-2 Screw Projection measured from the top side of panel

PC Board Preparation

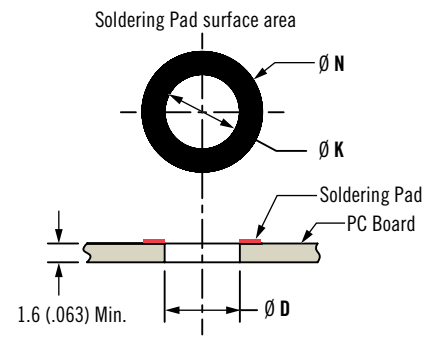

47 Captive Screws Styled knob series - SMT Style Screw as Shipped in Reel Pack

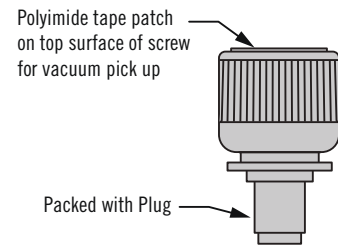

Thread Size	Part Number (Reel package shown)										Panel Preparation				
	Knurled Head		Smooth Head		H-1	H-2	P-1	P-2	ØB	ØJ	ØE	F*	ØK	ØN	ØD
	Phillips / Slotted	TORX® / Slotted	Phillips / Slotted	TORX® / Slotted											
M3 x 0.5	47-SM-3311-K-R	47-SM-3411-K-R	47-SM-3311-N-R	47-SM-3411-N-R	11.4 (.45)	8.4 (.33)	1.4 (.05)	4.4 (.17)	10.7 (.42)	5.5 (.217)	7.6 (.30)	0.7 (.03)	5.6 (.22)	8.6 (.34)	5.6 +0.08/-0 (.220 +.003/-0.000)
	47-SM-3321-K-R	47-SM-3421-K-R	47-SM-3321-N-R	47-SM-3421-N-R			1.4 (.05)	4.4 (.17)							
4-40	47-SM-1311-K-R	47-SM-1411-K-R	47-SM-1311-N-R	47-SM-1411-N-R	15.5 (.61)	10.7 (.42)	1.4 (.05)	4.4 (.17)	11.4 (.45)	6.2 (.244)	8.1 (.32)	0.7 (.03)	6.4 (.25)	10.2 (.40)	6.4 +0.08/-0 (.252 +.003/-0.000)
	47-SM-1321-K-R	47-SM-1421-K-R	47-SM-1321-N-R	47-SM-1421-N-R			2.2 (.09)	5.2 (.20)							
6-32	47-SM-2311-K-R	47-SM-2411-K-R	47-SM-2311-N-R	47-SM-2411-N-R	15.5 (.61)	10.7 (.42)	0.8 (.03)	5.6 (.22)	11.4 (.45)	6.2 (.244)	8.1 (.32)	0.7 (.03)	6.4 (.25)	10.2 (.40)	6.4 +0.08/-0 (.252 +.003/-0.000)
	47-SM-2321-K-R	47-SM-2421-K-R	47-SM-2321-N-R	47-SM-2421-N-R			2.3 (.09)	7.1 (.28)							

TORX® is a registered trademark of CAMCAR Innovations

4C-SM Captive Screws

Prism series · Surface Mount Technology (SMT) Style



Recess Styles

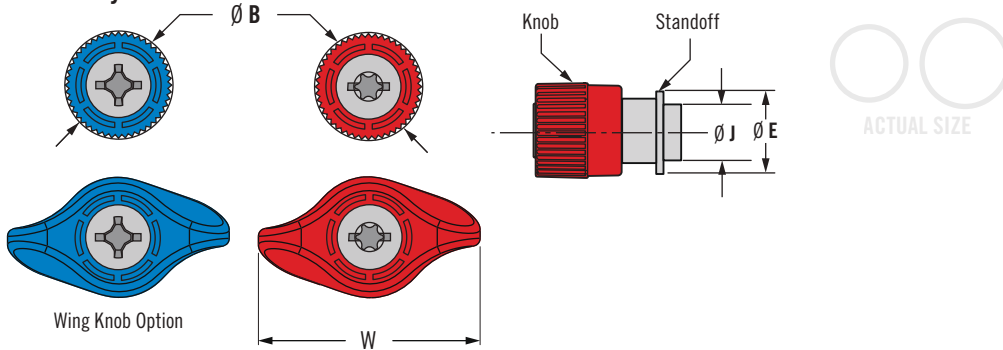

No. 2 Phillips Recess (M3,4-40) T10 TORX® / Slot Combination (M3,4-40)
 No. 2 Phillips / Slot Recess (6-32) T15 TORX® / Slot Combination(6-32)

PC Board Preparation

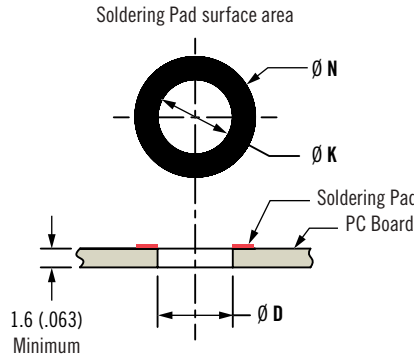

Knob Height and Screw Projection

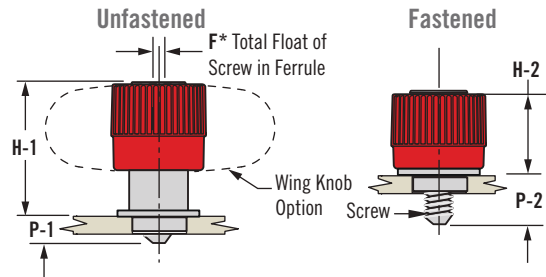

F* Value represents float in unfastened position
 Notes: P-1, P-2 Screw Projection measured from the top side of panel

- For installation to PC Board material utilizing surface mount technology
- Designate access points with color
- Color match captive screws to your industrial design
- High strength screw for use with high torque drivers

Material and Finish

Standoff: Steel, Tin plated
 Knob: High heat resistant plastic
 Screw: Hardened carbon steel, zinc plated, chromate, plus sealer
 Internal spring: 300 series stainless steel passivated
 Plug: Silicone rubber

Installation Notes

See page 551

To ensure you receive SOUTHCO® quality parts, look for the segmented circle

Part Number

See table

Screw as Shipped in Reel Pack

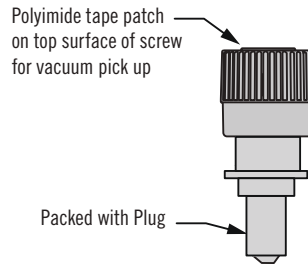

Thread Size	Part Number (Reel package shown)																Panel Preparation		
	Knurled Head				Smooth Head				H-1	H-2	P-1	P-2	Ø B	Ø J	Ø E	F*		Ø K	Ø N
	Phillips	TORX® / Slotted	Phillips	TORX® / Slotted	Ø D														
M3 x 0.5	4C-SM-3111-K000-R	4C-SM-3411-K000-R	4C-SM-3111-N000-R	4C-SM-3411-N000-R	10.8 (.43)	8.6 (.34)	3.3 (.13)	5.5 (.22)	9.7 (.38)	5.5 (.217)	7.6 (.30)	0.7 (.03)	5.6 (.22)	8.6 (.34)	20 (.7878)	5.6 +0.08/-0 (.220 +.003/-0.000)			
	4C-SM-3121-K000-R	4C-SM-3421-K000-R	4C-SM-3121-N000-R	4C-SM-3421-N000-R															
4-40	4C-SM-1111-K000-R	4C-SM-1411-K000-R	4C-SM-1111-N000-R	4C-SM-1411-N000-R	10.8 (.43)	8.6 (.34)	3.3 (.13)	5.5 (.22)	9.7 (.38)	5.5 (.217)	7.6 (.30)	0.7 (.03)	5.6 (.22)	8.6 (.34)	20 (.7878)	5.6 +0.08/-0 (.220 +.003/-0.000)			
	4C-SM-1121-K000-R	4C-SM-1421-K000-R	4C-SM-1121-N000-R	4C-SM-1421-N000-R															
6-32	4C-SM-2311-K000-R	4C-SM-2411-K000-R	4C-SM-2311-N000-R	4C-SM-2411-N000-R	16.3 (.64)	11.7 (.46)	0.1 (.004)	4.6 (.18)	11.4 (.45)	6.2 (.244)	8.1 (.32)	0.8 (.03)	6.4 (.25)	10.2 (.40)	24 (.945)	6.4 +0.08/-0 (.252 +.003/-0.000)			
	4C-SM-2321-K000-R	4C-SM-2421-K000-R	4C-SM-2321-N000-R	4C-SM-2421-N000-R															

TORX® is a registered trademark of CAMCAR Innovations



47/4C Captive Screws

ATCA captive screws

- M3 thread
- No. 2 Phillips recess
- Color match available

Material and Finish

Screw, ferrule and internal spring stainless steel, knob aluminum or Plastic

Performance Details

Flammability rating: UL94-V0
ATCA R3.0 compliant screw

Installation Notes

Please refer to installation drawings on www.southco.com for reference on dimensions **B***, \varnothing **D*** and \varnothing **Z***

F* indicates maximum float in the unfastened position

Part Number

See table

Specifying Color:

To indicate color, change the last three digits of the part number.

Example:

47-99-945-1P0-K000, black

47-99-945-1P0-K013, red

Metal Version

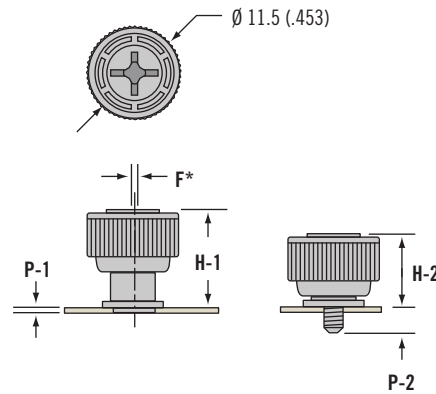

Overmolded Version

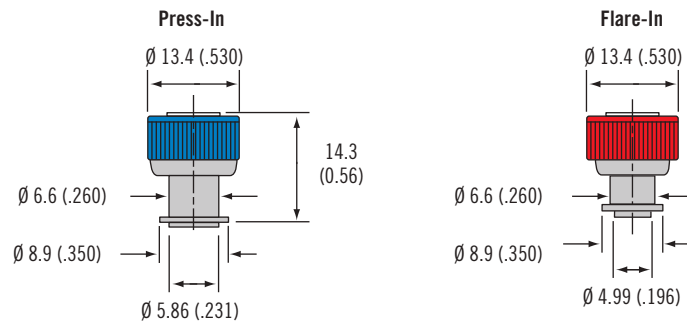

000 Black



008 Blue

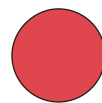

013 Red

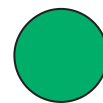

014 Green

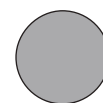

Your color
(contact Southco)

Series	Installation Method	Panel Thickness			Part Number No. 2 Phillips	H-1	H-2	P-1	P-2	F*	Panel Preparation	
		A Min.	A Max.	B*							\varnothing D*	\varnothing Z*
ATCA compliant (Metal Version)	Press-in	0.9 (.036)	~	~	47-99-945-1P0	14.3 (.56)	10.1 (.40)	1.0 (.39)	5.0 (.20)	1 (.039)	5.95 ± 0.04 (.234 ± .002)	3.2 ^{+0.2} _{-0.1} (.125 ^{+0.008} _{-.004})
	Flare-in	0.8 (.031)	1.5 (.060)	0.4 (.016)	47-99-944-1F1	14.3 (.56)	10.1 (.40)	1.0 (.39)	5.0 (.20)	1 (.039)	5.1 ^{+0.1} ₋₀ (.20 ^{+0.004} ₋₀)	3.0 ^{+0.1} ₋₀ (.118 ^{+0.004} _{-.000})
ATCA compliant (Overmolded Version)	Press-in	0.9 (.036)	~	~	47-99-945-1P0-K000	14.3 (.56)	10.1 (.40)	1.0 (.39)	5.0 (.20)	1 (.039)	5.95 ± 0.04 (.234 ± .002)	3.2 ^{+0.2} _{-0.1} (.125 ^{+0.008} _{-.004})
	Flare-in	0.8 (.031)	1.5 (.060)	0.4 (.016)	47-99-944-1F1-K000	14.3 (.56)	10.1 (.40)	1.0 (.039)	5.0 (.20)	1 (.039)	5.1 ^{+0.1} ₋₀ (.20 ^{+0.004} ₋₀)	3.0 ^{+0.1} ₋₀ (.118 ^{+0.004} _{-.000})

Installation Guidelines

for *SOUTHCO*[®] Self-Clinching products

Self-clinching product installation is offered on these *SOUTHCO*[®] products, making them easy-to-use captive panel fasteners:

- Captive Screws
- Receptacles for Quarter-turn Fasteners
- Receptacles for Fast-lead Thread Screws

When pressed into a properly prepared hole, self-clinching captive fasteners cold-flow (move) the panel material into the retaining groove of the fastener. This material then retains the fastener in the panel.

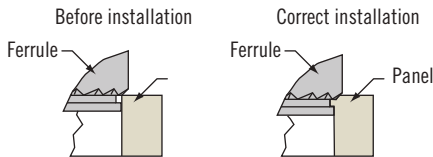

Successful press-in installations depend on:

Material:

The hardness of the panel material must not exceed *SOUTHCO*[®] recommendations. If the panel is too hard, the fastener will not install correctly.

Installation Holes:

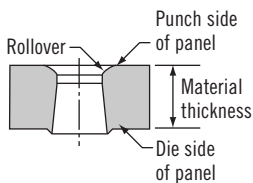
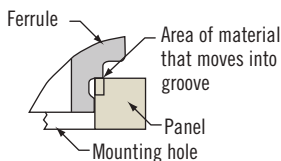

Mounting holes may be drilled, punched, or cast.

- Hole edge: the top hole edge must be sharp but with no broken edges.

Do not chamfer or debur edge.

- Punched holes: use a punch and die with a small clearance to minimize the rollover and fracture angle.
- Hole diameter: measure the hole diameter at the panel surface on the side on which the fastener will be installed. The diameter must be within *SOUTHCO*[®] specifications for that product.

- If the hole is too large, not enough material will flow into the retaining groove and the fastener may not be retained adequately.

- If the hole is too small, the fastener will not fit and installation may become difficult and unsafe.

- Hole distance from the edge of panel: the minimum recommended

distance is 1.5 x the diameter of the mounting hole, unless otherwise indicated.

- Installing too close to the edge will cause the material to flow in the opposite direction, deforming the edge of the panel. To install closer to the edge, you may need to restrain the panel edge.

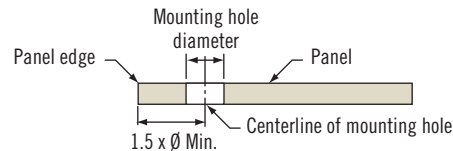

Panel Thickness:

The thickness of the panel at the mounting hole location must meet or exceed Southco's stated minimum recommendations.

If the material is too thin, panel deformation and/or damage to the fastener may result.

Installation is fast and easy if you follow these tips:

How to install: Use the recommended force where noted and a proper back-up tool.

- use any parallel-acting press
- use a punch whose diameter is larger than the head of the fastener

Installation Force: Proper installation requires an even distribution of adequate force. It does not depend on the distance the fastener is pressed into the panel.

- Southco does not recommend using a hammer. The impact force does not provide an even distribution of force to allow the panel material to completely flow into the fastener's retaining groove.
- Installation force varies from application to application, depending on the criteria noted above.

- On parts without a collar to provide a hard stop, press-in until the edge of the knurl is just barely visible.

When to Install:

Installation is recommended after plating or finishing has been applied to the panel.

The hole diameter must meet specifications before finish or plating is applied.

- Do not over-install parts. This interrupts the material and will reduce the retention strength.

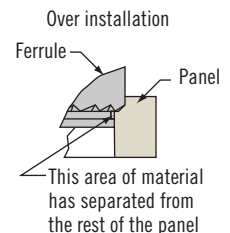



52-SM Captive Screws

Miniature series · Surface Mount Technology (SMT) Style

- For installation to PC Board material utilizing surface mount technology
- Smaller footprint for limited space applications
- Heat treated steel screw for optimum strength

Material and Finish

Screw: Hardened carbon steel, zinc plated, chromate, plus sealer
 Internal spring: 300 series stainless steel, passivated
 Standoff: Steel, Tin plated
 Plug: Silicone rubber

Installation Notes

See page 551

Part Number

See table

Recess Styles

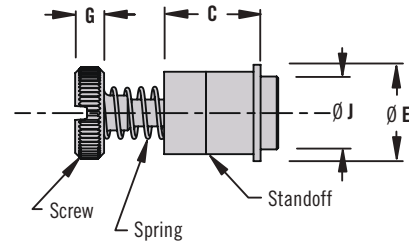
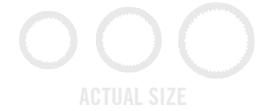
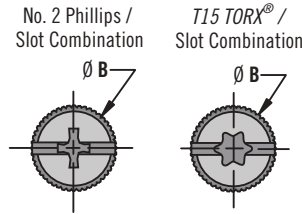

Screw Height and Screw Projection

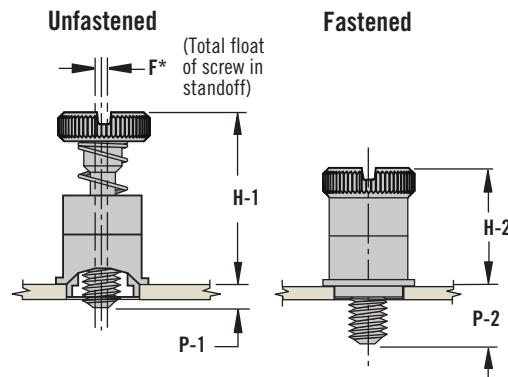

* Value represents float in unfastened position
 Notes: P-1, P-2 Screw Projection measured from the top side of panel

PC Board Preparation

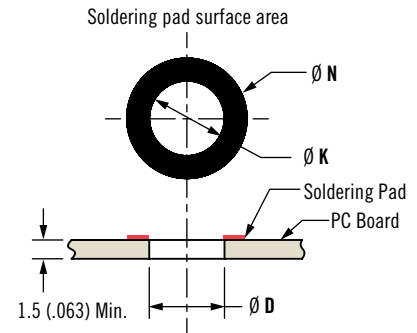

52 Captive Screws Miniature Series - SMT Style

Screw as Shipped in Reel Pack

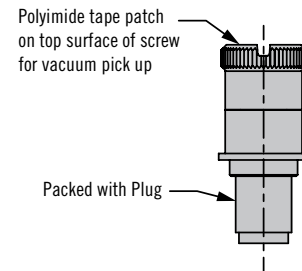

Thread Size	Part Number (Reel package shown)				H-1	H-2	P-1	P-2	Ø B Knurled Head	Ø B Smooth Head	Ø J	Ø E	C	G	F*	Ø K	Ø N	Panel Preparation Ø D
	Knurled Head		Smooth Head															
	Phillips / Slotted	TORX®/Slotted	Phillips / Slotted	TORX®/Slotted														
M3 x 0.5	52-SM-3311-K-R	52-SM-3411-K-R	52-SM-3311-N-R	52-SM-3411-N-R	14 (.55)	9.6 (.38)	0.8 (.03)	5.3 (.21)	7 (.28)	6.8 (.27)	5.5 (.217)	7.6 (.30)	7 (.28)	2.5 (.1)	0.5 (.02)	5.6 (.22)	8.6 (.34)	5.6 +0.08/-0 (.220 +.003/-0.000)
	52-SM-3321-K-R	52-SM-3421-K-R	52-SM-3321-N-R	52-SM-3421-N-R			2.3 (.09)	6.8 (.27)										
4-40	52-SM-1311-K-R	52-SM-1411-K-R	52-SM-1311-N-R	52-SM-1411-N-R	14 (.55)	9.6 (.38)	0.8 (.03)	5.3 (.21)	7 (.28)	6.8 (.27)	5.5 (.217)	7.6 (.30)	7 (.28)	2.5 (.1)	0.5 (.02)	5.6 (.22)	8.6 (.34)	5.6 +0.08/-0 (.220 +.003/-0.000)
	52-SM-1321-K-R	52-SM-1421-K-R	52-SM-1321-N-R	52-SM-1421-N-R			2.3 (.09)	6.8 (.27)										
6-32	52-SM-2311-K-R	52-SM-2411-K-R	52-SM-2311-N-R	52-SM-2411-N-R	15.7 (.62)	10.7 (.42)	0.7 (.028)	5.8 (.23)	7.9 (.31)	7.6 (.30)	6.2 (.244)	8.1 (.32)	8.1 (.32)	2.5 (.1)	0.8 (.03)	6.4 (.25)	10.2 (.40)	6.4 +0.08/-0 (.252 +.003/-0.000)
	52-SM-2321-K-R	52-SM-2421-K-R	52-SM-2321-N-R	52-SM-2421-N-R			2.2 (.087)	7.4 (.29)										

TORX® is a registered trademark of CAMCAR Innovations

Dimensions in millimeters (inch) unless otherwise stated



Southco Surface Mounted Technology (SMT) Captive Screws include installation and packaging features for installation onto PC Boards during the Reflow Process as a surface mounted device (SMD).

SMT product installation is offered on these Southco Captive Screws for 4-40, 6-32 and M3 thread sizes:

- 47 Styled Knob Series
- 4C Prism Series
- 52 Miniature Series

Installation Features

Each Southco SMT style captive screw includes a polyimide patch covering the screw head tool recess allowing for vacuum pick up during placement on the PC Board. The screw threads are protected from excess solder during the reflow process by a plug pre-assembled to the screw by Southco. The patch and plug are then removed after the final cool down phase.

Screw as Shipped in Reel or Tray Pack

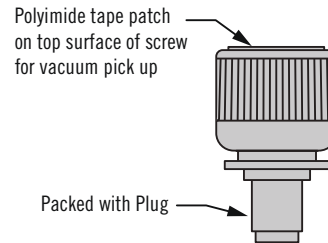

Preparing the PC Board to accept SMT Captive Screws

- See literature for optimum soldering pad surface area for the specific Southco Captive Screw being utilized

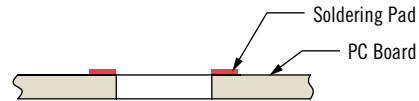

Packaging Features/Options

- Reel Pack



Reel Pack

Reflow Process

- Reflow of Solder
 - Pre-heat
 - Soak
 - Reflow
 - Cooling
- Cleaning
 - Remove excess solder paste



52 Captive Screws

Miniature series · Flare-in style

- Smaller footprint for limited space applications
- Heat treated steel screw for optimum strength

Material and Finish

Screw: Hardened carbon steel, zinc plated, chromate, plus sealer

Spring: 300 series stainless steel, passivated

Standoff: Aluminum natural

Installation tool: Hardened carbon steel, zinc plated, chromate, plus sealer

Installation Notes

1. Prepare panel as shown
2. Use light pressure to flare standoff, assuring parallel surfaces on the punch and installation tool

Recess Styles

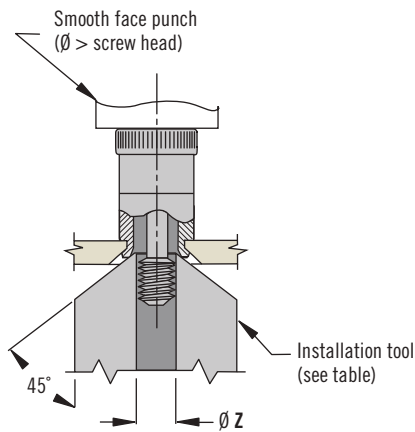
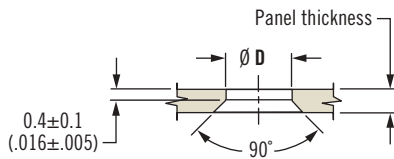
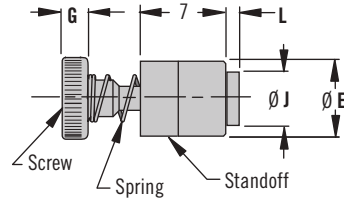
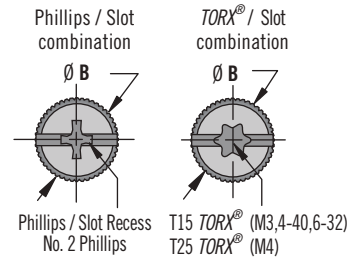

Knob Height and Screw Projection

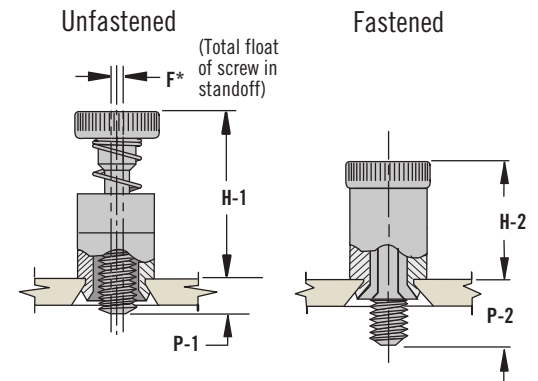

F* - Value represents float in unfastened position
 Notes: P-1, P-2 measured from the top side of panel

Part Number

See table

Thread Size	Panel Thickness		Part Number				Ø B	Ø E	F	G	H-1	H-2	Ø J	L	P-1	P-2	Panel Preparation		Tool Part No.
			Knurled Head		Smooth Head												Ø D	Ø Z	
	Min.	Max.	Phillips / Slotted	TORX® / Slotted	Phillips / Slotted	TORX® / Slotted													
4-40	0.8 (.031)	2.4 (.094)	52-19-11-4	52-17-11-4	52-1A-11-4	52-18-11-4	7 (.28)	6.2 (.245)	0.5 (.018)	2.5 (.1)	14 (.55)	9.6 (.38)	4.6 (.183)	1 (.041)	0.8 (.031)	5.3 (.21)	4.75 ^{+0.08} ₋₀ (.187 ^{+0.003} ₋₀)	3 (.120)	47-104
6-32	1.5 (.058)	3.2 (.125)	52-29-21-4	52-27-21-4	52-2A-21-4	52-28-21-4	8 (.31)	7 (.28)	0.7 (.028)	2.5 (.1)	15 (.59)	9.6 (.38)	5.3 (.209)	1.8 (.07)	1.8 (.07)	6.8 (.27)	5.41 ^{+0.08} ₋₀ (.213 ^{+0.003} ₋₀)	3.6 (.141)	47-106
M3 x 0.5	0.8 (.031)	2.4 (.094)	52-39-11-4	52-37-11-4	52-3A-11-4	52-38-11-4	7 (.28)	6.2 (.245)	0.6 (.023)	2.5 (.1)	14 (.55)	9.6 (.38)	4.6 (.183)	1 (.041)	0.8 (.031)	5.3 (.21)	4.75 ^{+0.08} ₋₀ (.187 ^{+0.003} ₋₀)	3 (.120)	47-104
M4 x 0.7	1.5 (.058)	3.2 (.125)	52-49-21-4	52-47-21-4	52-4A-21-4	52-48-21-4	9.4 (.37)	8.7 (.34)	0.7 (.028)	3 (.12)	15.2 (.60)	10.1 (.40)	6.7 (.26)	1.8 (.07)	1.8 (.07)	6.8 (.27)	6.76 ^{+0.1} _{-0.04} (.266 ^{+0.005} ₋₀)	4.2 (.166)	47-108

Note: Subtract .25 (.01) from Ø B for smooth head style.
 TORX® is a registered trademark of CAMCAR Innovations

Dimensions in millimeters (inch) unless otherwise stated

52 Captive Screws

Miniature series · Press-in style



Recess Styles

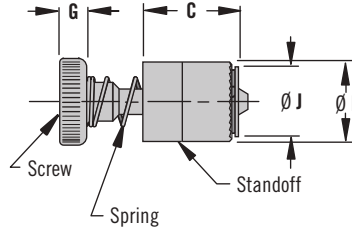
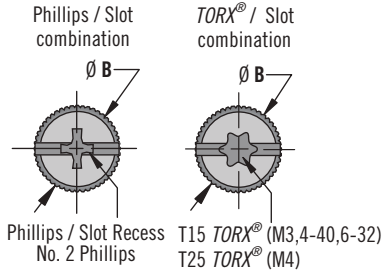

- Smaller footprint for limited space applications
- Heat treated steel screw for optimum strength

Material and Finish

Screw: Hardened carbon steel, zinc plated, chromate, plus sealer
 Spring: 300 series stainless steel, passivated
 Standoff: Carbon steel, zinc plated, chromate, plus sealer

Installation Notes

For use in most aluminum or in low carbon steels that are 1/4 hard or softer

Knob Height and Screw Projection

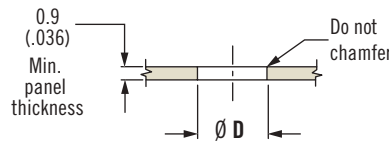
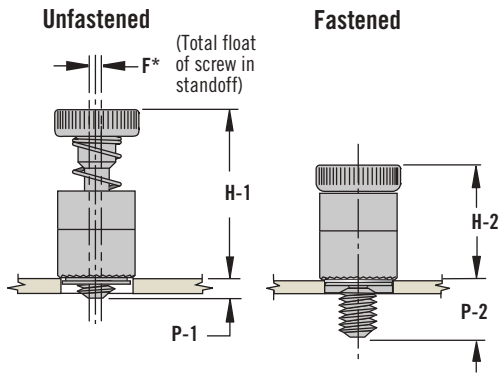

Notes: Recommended minimum distance from edge of panel to centerline of hole is $1.5 \times \varnothing D$ for press-in version.

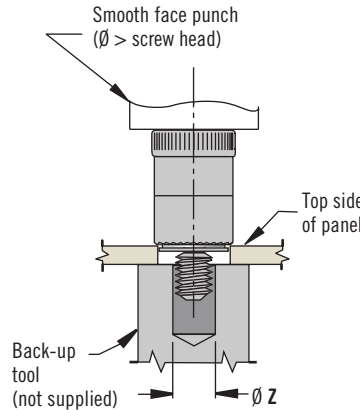

* Value represents float in unfastened position
 Notes: P-1, P-2 measured from the top side of panel



See page 627 for additional installation guidelines

Part Number

See table

Thread Size	Part Number				$\varnothing B$	C	$\varnothing E$	F*	G	H-1	H-2	$\varnothing J$	P-1	P-2	Panel Preparation	
	Knurled Head		Smooth Head												$\varnothing D$	$\varnothing Z$
	Phillips / Slotted	TORX® / Slotted	Phillips / Slotted	TORX® / Slotted												
4-40	52-19-51-4	52-17-51-4	52-1A-51-4	52-18-51-4	7 (.28)	7.9 (.31)	6.4 (.25)	0.5 (.018)	2.5 (.1)	14 (.55)	9.6 (.38)	5.5 (.217)	0.9 (.036) 2.5 (.1)	5.3 (.21) 6.8 (.27)	5.56 ^{+0.08} ₀ (.219 ^{+0.003} ₋₀)	3 (.120)
	52-19-53-4	52-17-53-4	52-1A-53-4	52-18-53-4												
6-32	52-29-51-4	52-27-51-4	52-2A-51-4	52-28-51-4	8 (.31)	8.6 (.34)	7 (.28)	0.7 (.028)	2.5 (.1)	15.5 (.61)	10.4 (.41)	6.3 (.247)	0.9 (.036) 2.5 (.1)	6.1 (.24) 7.6 (.30)	6.35 ^{+0.08} ₀ (.250 ^{+0.003} ₋₀)	3.7 (.144)
	52-29-53-4	52-27-53-4	52-2A-53-4	52-28-53-4												
M3 X 0.5	52-39-51-4	52-37-51-4	52-3A-51-4	52-38-51-4	7 (.28)	7.9 (.31)	6.4 (.25)	0.6 (.023)	2.5 (.1)	14 (.55)	9.6 (.38)	5.5 (.217)	0.9 (.036) 2.5 (.1)	5.3 (.21) 6.8 (.27)	5.56 ^{+0.08} ₀ (.219 ^{+0.003} ₋₀)	3.2 (.126)
	52-39-53-4	52-37-53-4	52-3A-53-4	52-38-53-4												
M4 X 0.7	52-49-51-4	52-47-51-4	52-4A-51-4	52-48-51-4	9.4 (.37)	8.6 (.34)	8.7 (.34)	0.7 (.028)	3 (.12)	16 (.63)	10.8 (.43)	7.9 (.31)	0.9 (.036) 2.5 (.1)	6.1 (.24) 7.6 (.30)	8 ⁺⁰ _{-0.08} (.315 ⁺⁰ _{-0.003})	4.4 (.173)
	52-49-53-4	52-47-53-4	52-4A-53-4	52-48-53-4												

TORX® is a registered trademark of CAMCAR Innovations



52 Overmold Captive Screws

Miniature series · Flare-in style

- Smaller footprint for limited space applications
- Heat treated steel screw for optimum strength
- Designate access points with color
- Color match captive screws to your industrial design

Material and Finish

Screw: Hardened carbon steel, zinc plated, chromate, plus sealer

Spring: 300 series stainless steel, passivated

Standoff: Aluminum natural

Knob: PC/ABS

Installation tool: Hardened carbon steel, zinc plated, chromate, plus sealer

Performance Details

Flamability Rating: UL94-V0

Installation Notes

1. Prepare panel as shown
2. Use light pressure to flare standoff, assuring parallel surfaces on the punch and installation tool

Part Number

See table

Recess Styles*

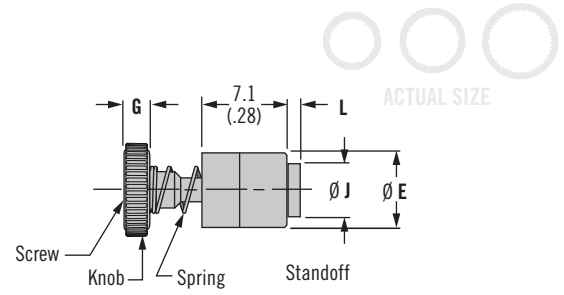
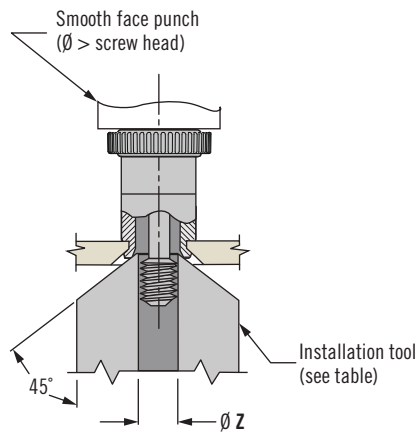
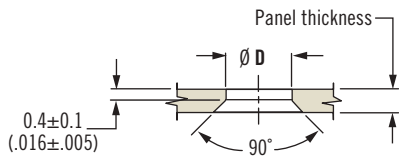
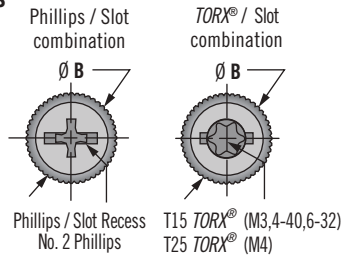

Knob Height and Screw Projection

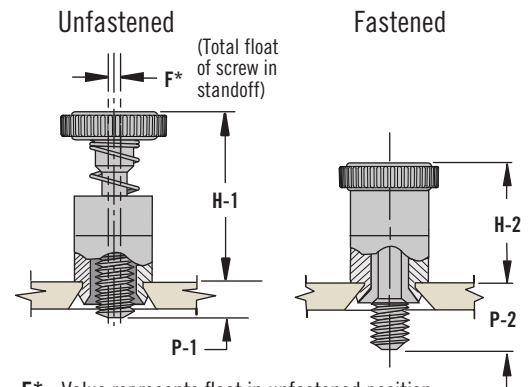

F* - Value represents float in unfastened position
Notes: P-1, P-2 measured from the top side of panel

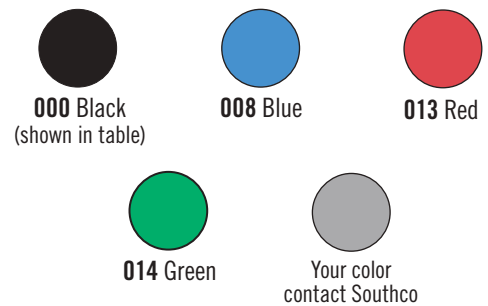

Specifying Color: To indicate color, change the last three digits of the part number

Example: 52-11-11-4-000 Black, 52-11-11-4-013 Red

Thread Size	Panel Thickness		Part Number														Panel Preparation		Tool Part No.			
			Knurled Head				Smooth Head				B Knurled Head	B Smooth Head	Ø E	F	G	H-1	H-2	Ø J		L	P-1	P-2
	Min.	Max.	Phillips / Slotted	TORX® / Slotted	Phillips / Slotted	TORX® / Slotted																
4-40	0.8 (.031)	2.4 (.094)	52-11-11-4-000 *	52-15-11-4-000 *	52-13-11-4-000 *	52-16-11-4-000 *	8.1 (.32)	7.8 (.31)	6.2 (.245)	0.5 (.018)	2.5 (.1)	14 (.55)	9.6 (.38)	4.6 (.183)	1 (.041)	0.8 (.031)	5.3 (.21)	4.75 ^{+0.08} ₋₀ (.187 ^{+0.003} ₋₀)	3 (.120)	47-104		
6-32	1.5 (.058)	3.2 (.125)	52-29-21-4-000	52-27-21-4-000	52-2A-21-4-000	52-28-21-4-000	8.8 (.35)	8.5 (.33)	7 (.28)	0.7 (.028)	2.5 (.1)	15 (.59)	9.6 (.38)	5.3 (.209)	1.8 (.07)	1.8 (.07)	6.8 (.27)	5.41 ^{+0.08} ₋₀ (.213 ^{+0.003} ₋₀)	3.6 (.141)	47-106		
M3 x 0.5	0.8 (.031)	2.4 (.094)	52-31-11-4-000 *	52-35-11-4-000*	52-33-11-4-000 *	52-36-11-4-000*	8.1 (.32)	7.8 (.31)	6.2 (.245)	0.6 (.023)	2.5 (.1)	14 (.55)	9.6 (.38)	4.6 (.183)	1 (.041)	0.8 (.031)	5.3 (.21)	4.75 ^{+0.08} ₋₀ (.187 ^{+0.003} ₋₀)	3 (.120)	47-104		
M4 x 0.7	1.5 (.058)	3.2 (.125)	52-49-21-4-000	52-45-21-4-000 *	52-4A-21-4-000	52-46-21-4-000 *	10.3 (.41)	10 (.39)	8.7 (.34)	0.7 (.028)	3 (.12)	15.2 (.60)	10 (.40)	6.7 (.26)	1.8 (.07)	1.8 (.07)	6.8 (.27)	6.76 ^{+0.1} ₋₀ (.266 ^{+0.005} ₋₀)	4.2 (.166)	47-108		

*Part Numbers not available with combination head styles; Phillips or TORX® only

TORX® is a registered trademark of CAMCAR Innovations

52 Overmold Captive Screws

Miniature series · Press-in style



Recess Styles*

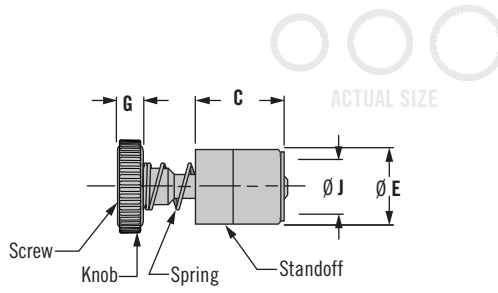
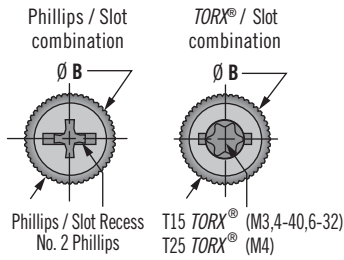

- Smaller footprint for limited space applications
- Heat treated steel screw for optimum strength
- Designate access points with color
- Color match captive screws to your industrial design

Knob Height and Screw Projection

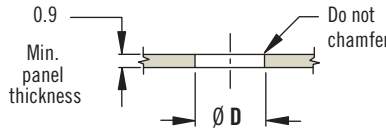
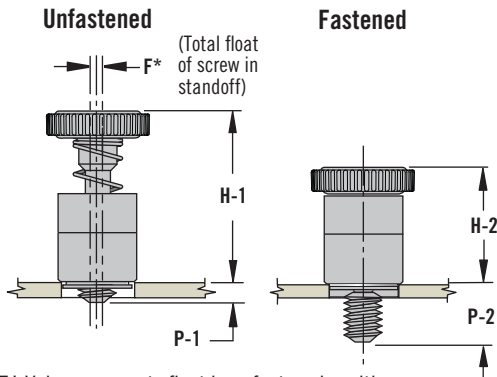

Notes: Recommended minimum distance from edge of panel to centerline of hole is 1.5 x Ø D for press-in version.

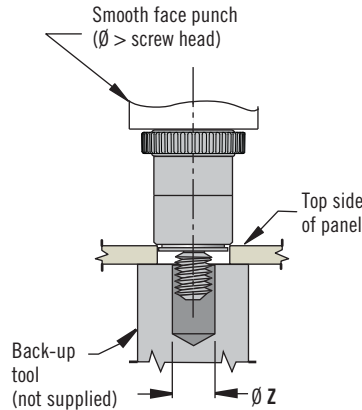

Material and Finish

Screw: Hardened carbon steel, zinc plated, chromate, plus sealer
 Spring: 300 series stainless steel, passivated
 Standoff: Carbon steel, zinc plated, chromate, plus sealer
 Knob: PC/ABS

Performance Details

Flamability Rating: UL94-V0

Installation Notes

For use in most aluminum or in low carbon steels that are 1/4 hard or softer. Visit www.southco.com for more information.

Part Number

See table

F* Value represents float in unfastened position
 Notes: P-1, P-2 measured from the top side of panel

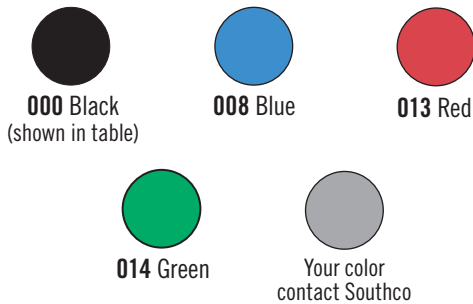

Specifying Color: To indicate color, change the last three digits of the part number

Example: 52-11-11-4-000 Black, 52-11-11-4-013 Red

Visit www.southco.com for additional installation guidelines

Thread Size	Part Number				B Knurled Head	B Smooth Head	C	Ø E	F*	G	H-1	H-2	Ø J	P-1	P-2	Panel Preparation	
	Knurled Head		Smooth Head													Ø D	Ø Z
	Phillips / Slotted	TORX® / Slotted	Phillips / Slotted	TORX® / Slotted													
4-40	52-11-51-4-000*	52-15-51-4-000*	52-13-51-4-000*	52-16-51-4-000*	8.1	7.8	7.9	6.4	0.5	2.5	14	9.6	5.5	0.9 (.036)	5.3 (.21)	5.56 ^{+0.08} ₀	3
	52-11-53-4-000*	52-15-53-4-000*	52-13-53-4-000*	52-16-53-4-000*	(.32)	(.31)	(.31)	(.25)	(.018)	(.1)	(.55)	(.38)	(.217)	2.5 (.1)	6.8 (.27)	(.219 ⁺⁰ _{-.003})	(.120)
6-32	52-29-51-4-000	52-27-51-4-000	52-2A-51-4-000	52-28-51-4-000	8.8	8.5	8.6	7	0.7	2.5	15.5	10.4	6.3	0.9 (.036)	6.1 (.24)	6.35 ^{+0.03} ₀	3.7
	52-29-53-4-000	52-27-53-4-000	52-2A-53-4-000	52-28-53-4-000	(.35)	(.33)	(.34)	(.28)	(.028)	(.1)	(.61)	(.41)	(.247)	2.5 (.1)	7.6 (.30)	(.250 ⁺⁰ _{-.003})	(.144)
M3 X 0.5	52-31-51-4-000*	52-35-51-4-000*	52-33-51-4-000*	52-36-51-4-000*	8.1	7.8	7.9	6.4	0.6	2.5	14	9.6	5.5	0.9 (.036)	5.3 (.21)	5.56 ^{+0.08} ₀	3.2
	52-31-53-4-000*	52-35-53-4-000*	52-33-53-4-000*	52-36-53-4-000*	(.32)	(.31)	(.31)	(.25)	(.023)	(.1)	(.55)	(.38)	(.217)	2.5 (.1)	6.8 (.27)	(.219 ^{+0.003} _{-.000})	(.126)
M4 X 0.7	52-49-51-4-000	52-45-51-4-000*	52-4A-51-4-000	52-46-51-4-000*	10.3	10	8.6	8.7	0.7	3	16	10.8	7.9	0.9 (.036)	6.1 (.24)	8 ⁺⁰ ₀	4.4 (.173)
	52-49-53-4-000	52-45-53-4-000*	52-4A-53-4-000	52-46-53-4-000*	(.41)	(.39)	(.34)	(.34)	(.028)	(.12)	(.63)	(.43)	(.31)	2.5 (.1)	7.7 (.30)	(.315 ⁺⁰ _{-.003})	

Note: *Part Numbers not available with combination head styles; Phillips or TORX® only

TORX® is a registered trademark of CAMCAR Innovations



52 Captive Screws

Miniature low profile series · Press-in style

- Low profile for limited space application
- Heat treated steel screw for optimum strength
- Designate access points with color
- Color match captive screws to your industrial design

Material and Finish

Screw: Hardened carbon steel, zinc plated, chromate, plus sealer

Spring: 300 series stainless steel, passivated

Standoff: Carbon steel, zinc plated, chromate, plus sealer

Prism: PC/ABS

Performance Details

Flamability Rating: UL94-V0

Installation Notes

For use in most aluminum or low carbon steels that are 1/4 hard or softer. Visit www.southco.com for more information.

Part Number

See table

Recess Styles

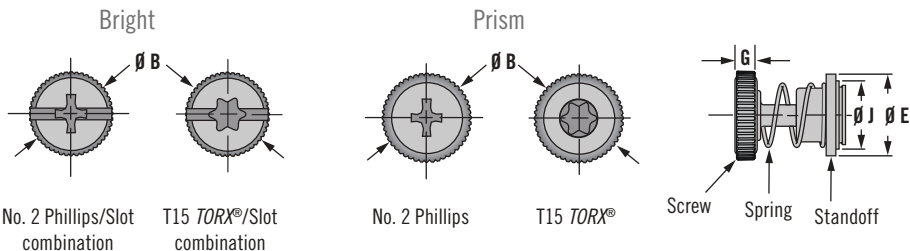

Knob Height and Screw Projection

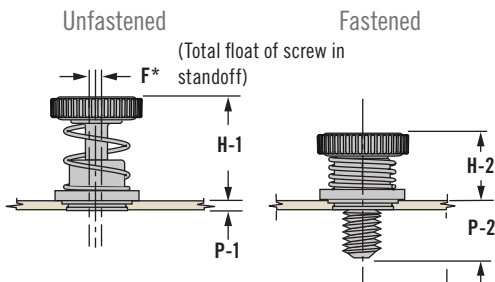

F* - Value represents float in unfastened position
Notes: P-1, P-2 measured from the top side of panel

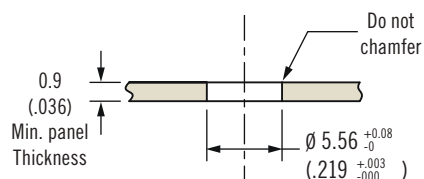

Notes: Recommended minimum distance from edge of panel to centerline of hole is 1.5 x Ø for press-in version.

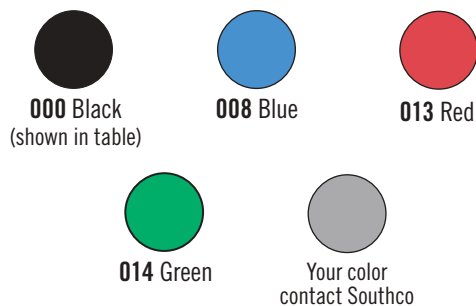

Specifying Color: To indicate color, change the last three digits of the part number
Example: 52-A11-51-4-000 Black, 52-A11-51-4-013 Red

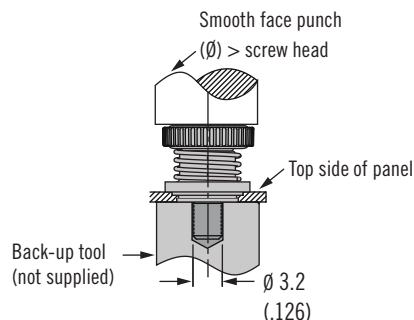

Visit www.southco.com for additional installation guidelines

Color/ Appearance	Thread Size	Part Number						H-1	H-2	P-1	P-2	Ø J	Ø E	G	F*
		Knurled Head			Smooth Head										
		Phillips / Slotted	TORX®/ Slotted	Ø B	Phillips / Slotted	TORX®/ Slotted	Ø B								
Bright	4-40	52-A19-51-4	52-A17-51-4	7	52-A1A-51-4	52-A18-51-4	6.75	9	6	0.9	3.9	6.35	7.6	1.7	0.5
	M3 x 0.5	52-A39-51-4	52-A37-51-4	(.28)	52-A3A-51-4	52-A38-51-4	(.27)	(.36)	(.24)	(.04)	(.17)	(.25)	(.3)	(.07)	(.02)
		Phillips	TORX®	Ø B	Phillips	TORX®	Ø B								
Prism (black shown)	4-40	52-A11-51-4-000	52-A15-51-4-000	8.1	52-A13-51-4-000	52-A16-51-4-000	7.8	9.5	6.2	0.9	3.9	6.35	7.6	2.2	0.5
	M3 x 0.5	52-A31-51-4-000	52-A35-51-4-000	(.32)	52-A33-51-4-000	52-A36-51-4-000	(.31)	(.37)	(.26)	(.04)	(.17)	(.25)	(.3)	(.09)	(.02)

TORX® is a registered trademark of CAMCAR Innovations

52 Captive Screws

Miniature low profile series · Surface Mount Technology (SMT) Style



Recess Styles

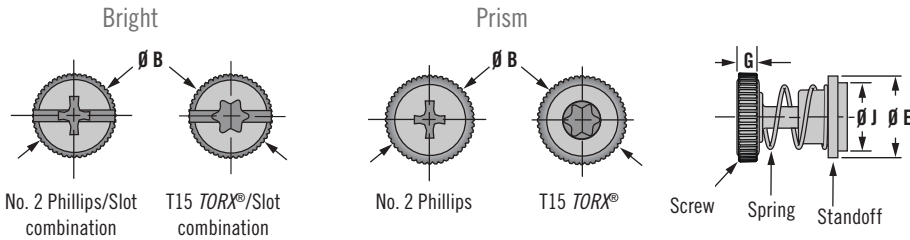

Knob Height and Screw Projection

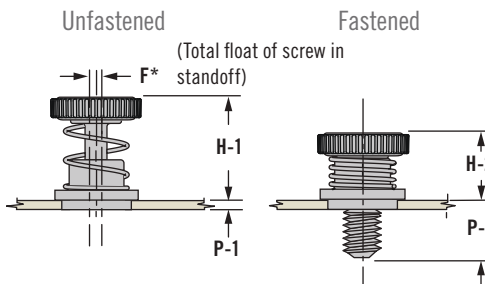

F* Value represents float in unfastened position
Notes: P-1, P-2 measured from the top side of panel

PC Board Preparation

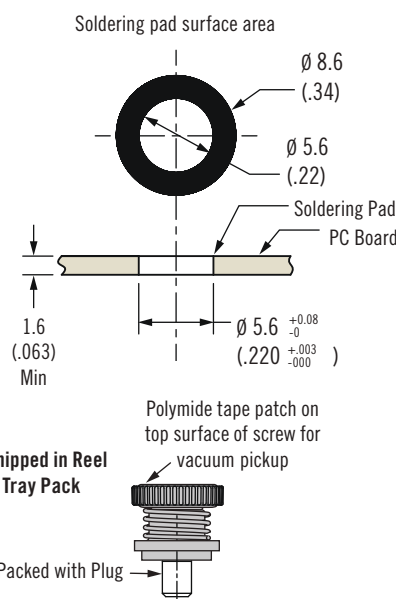

- For installation to PC Board material utilizing surface mount technology
- Heat treated steel screw for optimum strength
- Designate access points with color
- Color match captive screws to your industrial design

Material and Finish

Screw: Hardened carbon steel, zinc plated, chromate, plus sealer
Spring: 300 series stainless steel, passivated
Standoff: Carbon steel, tin plated, chromate, plus sealer
Prism: High heat resistant plastic

Performance Details

Flamability Rating: UL94-V0

Installation Notes

Visit www.southco.com for additional installation guidelines

Part Number

See table

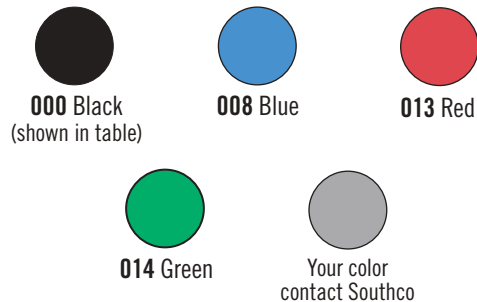

Specifying Color: To indicate color, change the last three digits of the part number

Example: 52-SM-A1111-K000-R, 52-SM-A1111-K013-R

Visit www.southco.com for additional installation guidelines

Screw as Shipped in Reel Pack or Tray Pack

Specify Package - SMT Style

Indicate package option with last digit of the part number

Example

52-SM-A1311-K-R: Reel Package (as shown in table)

52-SM-A1311-K-T: Tray Package

Color/ Appearance	Thread Size	Part Number						H-1	H-2	P-1	P-2	Ø J	Ø E	G	F*
		Knurled Head			Smooth Head										
		Phillips / Slotted	TORX®/ Slotted	Ø B	Phillips / Slotted	TORX®/ Slotted	Ø B								
Bright	4-40	52-SM-A1311-K-R	52-SM-A1411-K-R	7	52-SM-A1311-N-R	52-SM-A1411-N-R	6.75	8.4	5.4	1.5	4.5	5.5	7.6	1.7	0.5
	M3 x 0.5	52-SM-A3311-K-R	52-SM-A3411-K-R	(.28)	52-SM-A3311-N-R	52-SM-A3411-N-R	(.27)	(.33)	(.21)	(.06)	(.18)	(.22)	(.3)	(.07)	(.02)
		Phillips	TORX®	Ø B	Phillips	TORX®	Ø B								
Prism (black shown)	4-40	52-SM-A1111-K000-R	52-SM-A1211-K000-R	8.1	52-SM-A1111-N000-R	52-SM-A1211-N000-R	7.8	8.9	5.9	1.5	4.5	5.5	7.6	2.2	0.5
	M3 x 0.5	52-SM-A3111-K000-R	52-SM-A3211-K000-R	(.32)	52-SM-A3111-N000-R	52-SM-A3211-N000-R	(.31)	(.35)	(.23)	(.06)	(.18)	(.22)	(.3)	(.09)	(.02)

TORX® is a registered trademark of CAMCAR Innovations

Installation Guidelines

for *SOUTHCO*[®] Self-Clinching products

Self-clinching product installation is offered on these *SOUTHCO*[®] products, making them easy-to-use captive panel fasteners:

- Captive Screws
- Receptacles for Quarter-turn Fasteners
- Receptacles for Fast-lead Thread Screws

When pressed into a properly prepared hole, self-clinching captive fasteners cold-flow (move) the panel material into the retaining groove of the fastener. This material then retains the fastener in the panel.

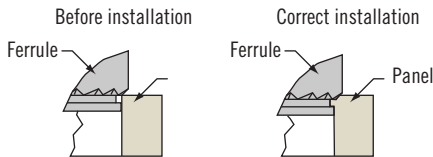

Successful press-in installations depend on:

Material:

The hardness of the panel material must not exceed *SOUTHCO*[®] recommendations. If the panel is too hard, the fastener will not install correctly.

Installation Holes:

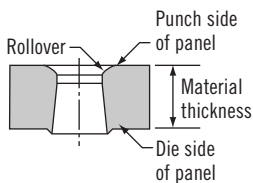
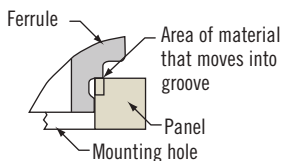

Mounting holes may be drilled, punched, or cast.

- Hole edge: the top hole edge must be sharp but with no broken edges.

Do not chamfer or debur edge.

- Punched holes: use a punch and die with a small clearance to minimize the rollover and fracture angle.
- Hole diameter: measure the hole diameter at the panel surface on the side on which the fastener will be installed. The diameter must be within *SOUTHCO*[®] specifications for that product.

- If the hole is too large, not enough material will flow into the retaining groove and the fastener may not be retained adequately.

- If the hole is too small, the fastener will not fit and installation may become difficult and unsafe.

- Hole distance from the edge of panel: the minimum recommended

- Spring-loaded Plungers
- Captive Nuts
- Threaded Inserts

distance is 1.5 x the diameter of the mounting hole, unless otherwise indicated.

- Installing too close to the edge will cause the material to flow in the opposite direction, deforming the edge of the panel. To install closer to the edge, you may need to restrain the panel edge.

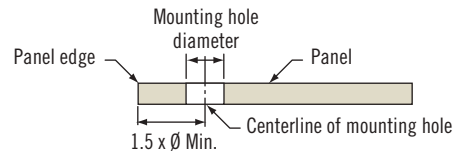

Panel Thickness:

The thickness of the panel at the mounting hole location must meet or exceed Southco's stated minimum recommendations.

If the material is too thin, panel deformation and/or damage to the fastener may result.

Installation is fast and easy if you follow these tips:

How to install: Use the recommended force where noted and a proper back-up tool.

- use any parallel-acting press
- use a punch whose diameter is larger than the head of the fastener

Installation Force: Proper installation requires an even distribution of adequate force. It does not depend on the distance the fastener is pressed into the panel.

- Southco does not recommend using a hammer. The impact force does not provide an even distribution of force to allow the panel material to completely flow into the fastener's retaining groove.
- Installation force varies from application to application, depending on the criteria noted above.

- On parts without a collar to provide a hard stop, press-in until the edge of the knurl is just barely visible.

When to Install:

Installation is recommended after plating or finishing has been applied to the panel.

The hole diameter must meet specifications before finish or plating is applied.

- Do not over-install parts. This interrupts the material and will reduce the retention strength.

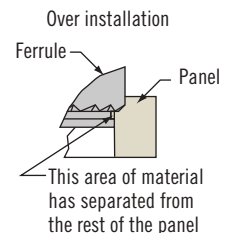



5T Captive Screws

Heat sink series

- Maximize heat transfer from components to heatsink
- Positive fastening under shock and vibration
- Fastener allows for thermal expansion of components under a set preload

Material and Finish

Screw: Hardened carbon steel, zinc plate, chromate plus sealer

Spring: 300 series stainless steel, passivated

Ferrule: Aluminum, natural

Performance Details

M3/4-40 Recommended Torque: 0.6 N \cdot m (5.3 in \cdot lbf)

M3.5/6-32 Recommended Torque: 1.08 N \cdot m (9.6 in \cdot lbf)

Installation Notes

1. Drill then countersink according to the required dimensions.
2. Insert screw assembly into prepared hole in panel. Place back-up tool as shown.
3. Place work under press, center tool over screw thread and flare ferrule into countersink in panel. Recommended load 2200 N.

Notes

Load applied by each screw: [3.4 (.13) * K] +7.57 N (1.7 lb)
 Standard K value shown in the table. Load at given deflection *shown in the fastened position above.

Part Number

See table

Unfastened

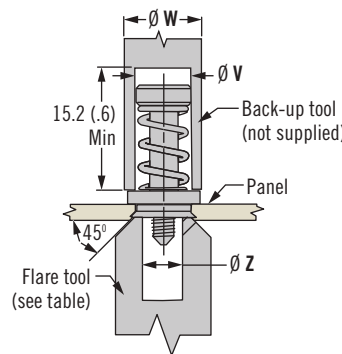
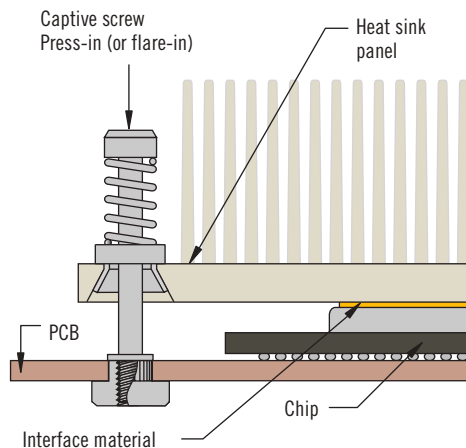
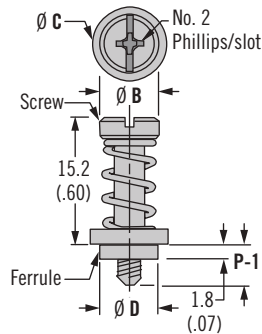

Fastened

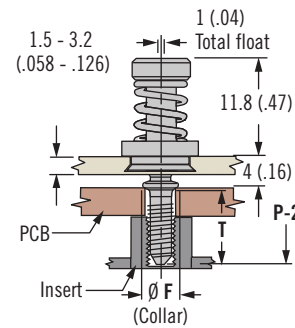

Standard

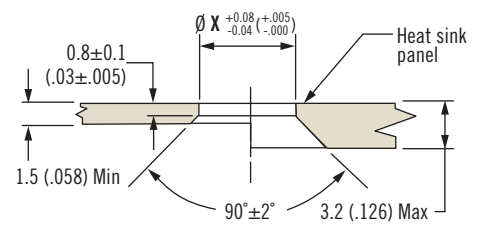

Alternate

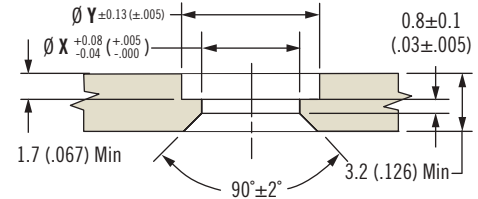

Thread Size	ø V	ø X	ø Y	ø W Min.	ø Z	Tool Part Number
M3 or 4-40	7.1 (.28)	6.8 (.27)	9.5 (.37)	9.5 (.37)	5.1 (.2)	47-115
M3.5 or 6-32	7.9 (.31)	7.1 (.28)	10.7 (.46)	10.7 (.42)	5.6 (.22)	5T-06-Tool

Thread Size	Part Number	Panel Thickness		Screw Projection		T	ø B	ø C	ø D	ø F	Spring Rate K N/mm (lbf/in)	Load Max.* N (lbf)
		Min.	Max.	P1	P-2							
M3	5T-11-M3-222-5	1.5 (.058)	3.2 (.126)	5.9 (.232)	8.4 (.331)	5 (.197)	6.8 (.27)	9 (.35)	6.7 (.294)	4.7 (.185)	4.45 (25.4)	22.5 (5)
4-40	5T-11-04-222-5			6.6 (.26)	9.9 (.39)	5.7 (.224)	7.6 (.30)	10.4 (.41)	7 (.275)	5 (.2)		
M3.5	5T-11-M35-222-5			6.6 (.26)	9.9 (.39)	5.7 (.224)	7.6 (.30)	10.4 (.41)	7 (.275)	5 (.2)		
6-32	5T-11-06-222-5											

Installation Guidelines

for *SOUTHCO*[®] Self-Clinching products

Self-clinching product installation is offered on these *SOUTHCO*[®] products, making them easy-to-use captive panel fasteners:

- Captive Screws
- Receptacles for Quarter-turn Fasteners
- Receptacles for Fast-lead Thread Screws

When pressed into a properly prepared hole, self-clinching captive fasteners cold-flow (move) the panel material into the retaining groove of the fastener. This material then retains the fastener in the panel.

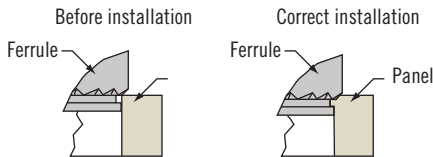

Successful press-in installations depend on:

Material:

The hardness of the panel material must not exceed *SOUTHCO*[®] recommendations. If the panel is too hard, the fastener will not install correctly.

Installation Holes:

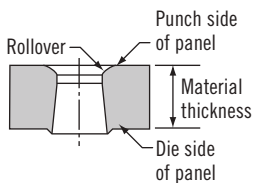
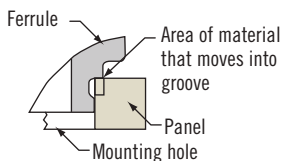

Mounting holes may be drilled, punched, or cast.

- Hole edge: the top hole edge must be sharp but with no broken edges.

Do not chamfer or debur edge.

- Punched holes: use a punch and die with a small clearance to minimize the rollover and fracture angle.
- Hole diameter: measure the hole diameter at the panel surface on the side on which the fastener will be installed. The diameter must be within *SOUTHCO*[®] specifications for that product.

- If the hole is too large, not enough material will flow into the retaining groove and the fastener may not be retained adequately.

- If the hole is too small, the fastener will not fit and installation may become difficult and unsafe.

- Hole distance from the edge of panel: the minimum recommended

distance is 1.5 x the diameter of the mounting hole, unless otherwise indicated.

- Installing too close to the edge will cause the material to flow in the opposite direction, deforming the edge of the panel. To install closer to the edge, you may need to restrain the panel edge.

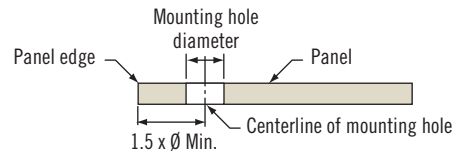

Panel Thickness:

The thickness of the panel at the mounting hole location must meet or exceed Southco's stated minimum recommendations.

If the material is too thin, panel deformation and/or damage to the fastener may result.

Installation is fast and easy if you follow these tips:

How to install: Use the recommended force where noted and a proper back-up tool.

- use any parallel-acting press
- use a punch whose diameter is larger than the head of the fastener

Installation Force: Proper installation requires an even distribution of adequate force. It does not depend on the distance the fastener is pressed into the panel.

- Southco does not recommend using a hammer. The impact force does not provide an even distribution of force to allow the panel material to completely flow into the fastener's retaining groove.
- Installation force varies from application to application, depending on the criteria noted above.

- On parts without a collar to provide a hard stop, press-in until the edge of the knurl is just barely visible.

When to Install:

Installation is recommended after plating or finishing has been applied to the panel.

The hole diameter must meet specifications before finish or plating is applied.

- Do not over-install parts. This interrupts the material and will reduce the retention strength.

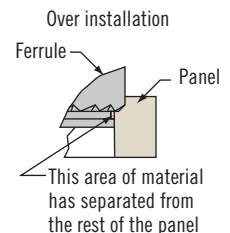

F5 Captive Screws

Flush series

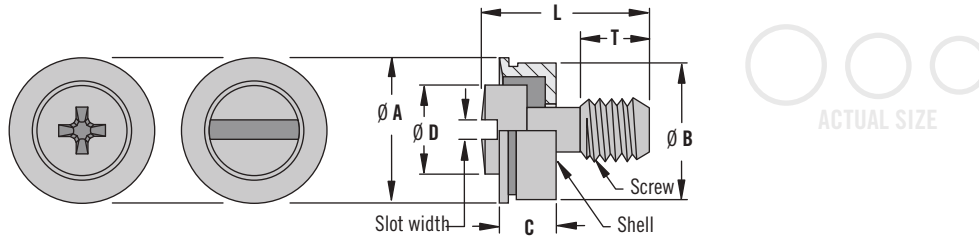

Installation

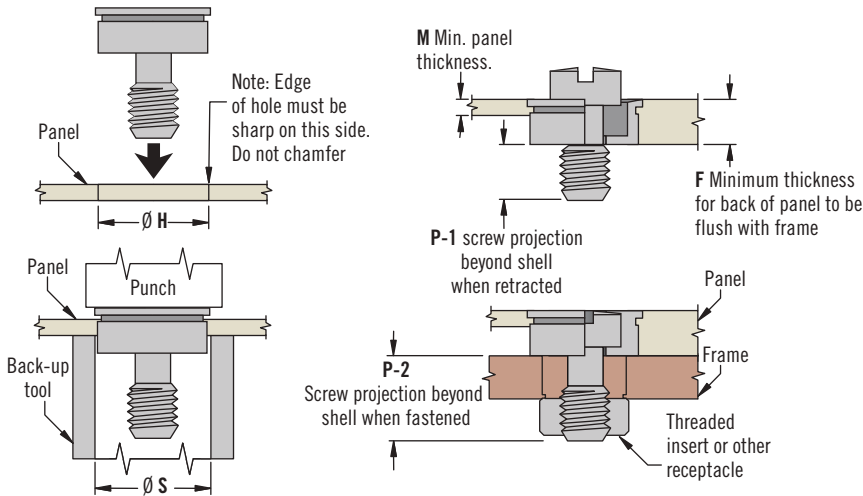

- Flush when fastened

Material and Finish

Shell: 303 Stainless steel, passivated

Screw:

Slotted: 303 stainless steel, passivated.

Phillips: 430 stainless steel, passivated

Notes

For use in most aluminums or in low carbon steels that are 1/4 hard or softer

Screws will float 0.5 (.02) total movement

Shipped assembled

Part Number

See table

Thread Size	Max. Recommended Tightening Torque
M3/ 4-40	0.6 N \cdot m (5in \cdot lbf)
6-32	1.6 N \cdot m (14in \cdot lbf)
M4/ 8-32	2.8 N \cdot m (25in \cdot lbf)

See page 627 for additional installation guidelines

Recess Style	Thread Size	Screw Dimensions					Slot Width	Screw Length L	Part Number		Screw Projection Beyond Outer Surface of Panel		Installation Dimensions			
		Ø A	Ø B	C	Ø D	T			Metric	Imperial	P-1	P-2	Ø H	M	F	Ø S
Phillips	M4 x 0.7 or UNC 8-32	10.1 (.40)	9.45 (.373)	3.1 (.122)	6.4 (.25)	4.3 (.17)	~	8.6 (.34)	F5-M4-P2	F5-832-P2	4.3 (.17)	5.6 (.22)	9.5 ^{+0.08} ₋₀ (.375 ^{+0.003} ₋₀)	1.5 (.060)	3.2 (.125)	9.6 ^{+0.1} _{-0.05} (.379 ^{+0.004} _{-0.002})
								9.6 (.38)	F5-M4-P4	F5-832-P4		6.6 (.26)				
								10.6 (.42)	F5-M4-P6	F5-832-P6		7.6 (.30)				
								11.6 (.46)	F5-M4-P8	F5-832-P8		8.6 (.34)				
Slotted	M3 x 0.5 or UNC 4-40	7.1 (.28)	6.45 (.254)	1.7 (.067)	4 (.16)	3.8 (.15)	0.9 (.035)	5.8 (.23)	F5-90-402-20	F5-60-402-20	3.8 (.15)	4.1 (.16)	6.5 ^{+0.08} ₋₀ (.257 ^{+0.002} _{-0.001})	1.3 (.050)	1.8 (.070)	6.6 ^{+0.1} _{-0.05} (.260 ^{+0.004} _{-0.002})
								7.9 (.31)	F5-90-406-20	F5-60-406-20		6.1 (.24)				
	UNC 6-32	8.1 (.32)	7.44 (.293)	2 (.082)	4.8 (.19)	3.8 (.15)	1 (.039)	6.4 (.25)	~	F5-60-602-20	3.8 (.15)	4.3 (.17)	7.5 ^{+0.08} ₋₀ (.295 ^{+0.003} ₋₀)	1.4 (.055)	2.2 (.085)	7.6 ^{+0.1} _{-0.05} (.299 ^{+0.004} _{-0.002})
								8.4 (.33)	~	F5-60-606-20		6.4 (.25)				
								9.4 (.37)	~	F5-60-608-20		7.4 (.29)				
	M4 x 0.7 or UNC 8-32	10.1 (.40)	9.45 (.373)	2.34 (.092)	6.4 (.25)	5.1 (.20)	1.1 (.045)	8.9 (.35)	F5-M40-14	F5-832-14	5.1 (.20)	6.6 (.26)	9.5 ^{+0.08} ₋₀ (.375 ^{+0.003} ₋₀)	1.5 (.060)	2.4 (.095)	9.6 ^{+0.1} _{-0.05} (.379 ^{+0.004} _{-0.002})
								9.9 (.39)	F5-M40-16	F5-832-16		7.6 (.30)				
								10.9 (.43)	F5-M40-18	F5-832-18		8.6 (.34)				

Installation Guidelines

for *SOUTHCO*[®] Self-Clinching products

Self-clinching product installation is offered on these *SOUTHCO*[®] products, making them easy-to-use captive panel fasteners:

- Captive Screws
- Receptacles for Quarter-turn Fasteners
- Receptacles for Fast-lead Thread Screws

When pressed into a properly prepared hole, self-clinching captive fasteners cold-flow (move) the panel material into the retaining groove of the fastener. This material then retains the fastener in the panel.

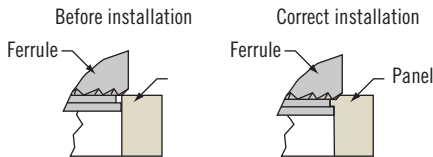

Successful press-in installations depend on:

Material:

The hardness of the panel material must not exceed *SOUTHCO*[®] recommendations. If the panel is too hard, the fastener will not install correctly.

Installation Holes:

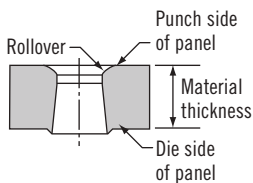
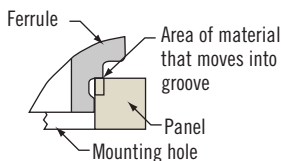

Mounting holes may be drilled, punched, or cast.

- Hole edge: the top hole edge must be sharp but with no broken edges.

Do not chamfer or debur edge.

- Punched holes: use a punch and die with a small clearance to minimize the rollover and fracture angle.
- Hole diameter: measure the hole diameter at the panel surface on the side on which the fastener will be installed. The diameter must be within *SOUTHCO*[®] specifications for that product.

- If the hole is too large, not enough material will flow into the retaining groove and the fastener may not be retained adequately.

- If the hole is too small, the fastener will not fit and installation may become difficult and unsafe.

- Hole distance from the edge of panel: the minimum recommended

distance is 1.5 x the diameter of the mounting hole, unless otherwise indicated.

- Installing too close to the edge will cause the material to flow in the opposite direction, deforming the edge of the panel. To install closer to the edge, you may need to restrain the panel edge.

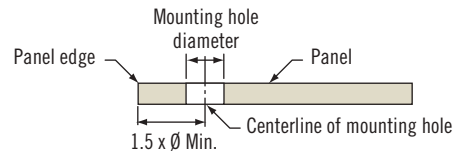

Panel Thickness:

The thickness of the panel at the mounting hole location must meet or exceed Southco's stated minimum recommendations.

If the material is too thin, panel deformation and/or damage to the fastener may result.

Installation is fast and easy if you follow these tips:

How to install: Use the recommended force where noted and a proper back-up tool.

- use any parallel-acting press
- use a punch whose diameter is larger than the head of the fastener

Installation Force: Proper installation requires an even distribution of adequate force. It does not depend on the distance the fastener is pressed into the panel.

- Southco does not recommend using a hammer. The impact force does not provide an even distribution of force to allow the panel material to completely flow into the fastener's retaining groove.
- Installation force varies from application to application, depending on the criteria noted above.

- On parts without a collar to provide a hard stop, press-in until the edge of the knurl is just barely visible.

When to Install:

Installation is recommended after plating or finishing has been applied to the panel.

The hole diameter must meet specifications before finish or plating is applied.

- Do not over-install parts. This interrupts the material and will reduce the retention strength.

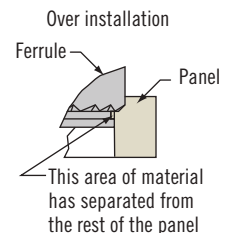

N7 Captive Nut

Thru hole and blind styles

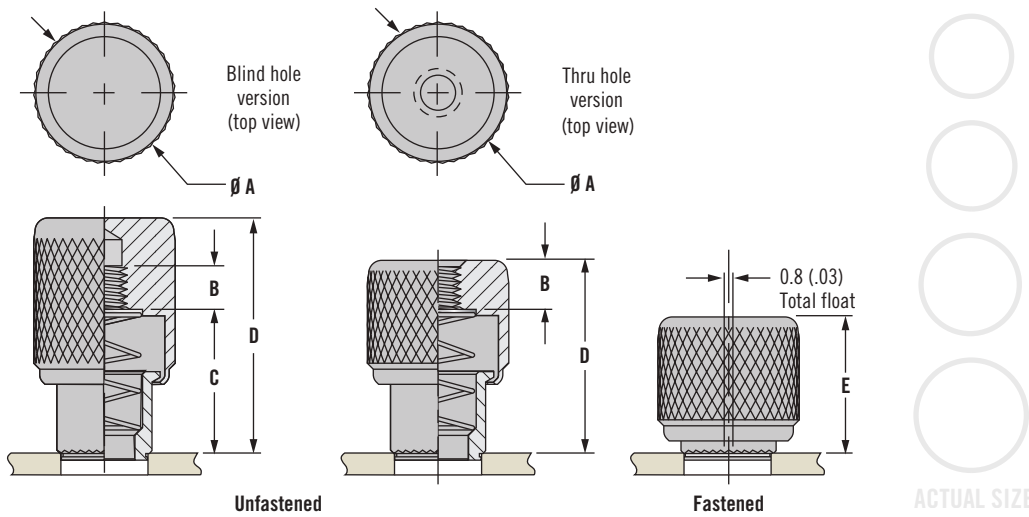

ACTUAL SIZE

Notes: For use in material hardnesses RB85 or less, such as low carbon steels that are half hard or softer, stainless steels in the annealed condition and aluminum.

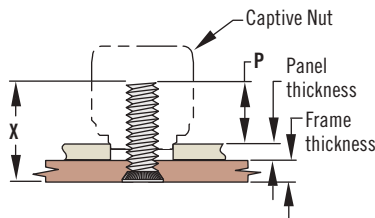

Thread Size	P Min.	P Max.
M3	7.1 (.28)	9.5 (.37)
M4	10 (.40)	12.1 (.47)
M5	10.2 (.41)	12.2 (.48)
M6	12.4 (.49)	16.7 (.66)
4-40	7.3 (.29)	9.4 (.37)
6-32	9.9 (.39)	13.1 (.51)
8-32	10.1 (.40)	13.3 (.52)
10-32	10.3 (.41)	13.5 (.53)
1/4-20	13 (.51)	16.5 (.65)

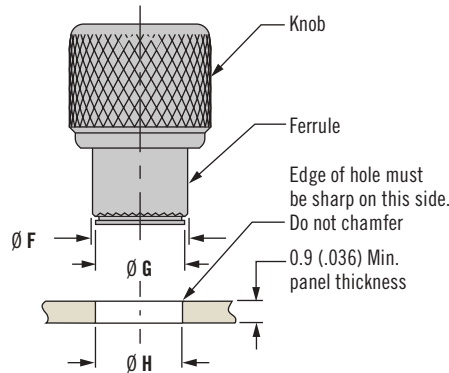

See page 627 for additional installation guidelines

Notes: Recommended minimum distance from edge of panel to centerline of hole is 1.5 x Ø H.

- Spring ejected
- Knurled knob provides solid grip
- Fastens to externally threaded studs
- Helps speed panel replacement

Material and Finish

Knob: Aluminum, natural

Ferrule: Hardened steel, zinc plate, chromate plus sealer

Spring: 302 Stainless steel, passivated

Installation Notes

1. Prepare hole in panel as shown
2. Provide a solid back-up surface behind the panel
3. Press the assembly into the panel until only the top of the knurl on the ferrule is visible

Threadstud insert selection for blind hole applications

Frame thickness + panel thickness + P Minimum = X Minimum

Frame thickness + panel thickness + P Maximum = X Maximum

Threadstud insert length (L): X Minimum < "L" > X Maximum

"L" values greater than X Maximum must use the thru hole version

If a weld stud is used, omit the frame thickness from the calculations (see the table and diagram to the right)

*The above dimensions are for blind hole captive nuts

Thread Size	Knob Style	Part Number		Ø A	B (Thread Length)	C	D	E	Ø F	Ø G	Ø H
		Metric	Inch								
	Min.	Natural	Natural								
M3 or 4-40	Thru hole	N7-02-10	N7-52-10	10.6 (.42)	3.6 (.14)	~	12.8 (.50)	9.3 (.37)	6.4 (.25)	5.5 (.22)	5.6±0.04 (.220±.002)
	Blind hole	N7-02-11	N7-52-11		4 (.16)	9.2 (.36)	16.8 (.66)	13.3 (.52)			
6-32 UNC	Thru hole	~	N7-62-10	11.4 (.45)	4.7 (.19)	~	17.7 (.70)	12.5 (.49)	7.1 (.28)	6.3 (.25)	6.4 ^{+0.03} _{-0.05} (+.001) (-.002)
	Blind hole	~	N7-62-11		5.4 (.21)	13 (.51)	23 (.91)	17.9 (.70)			
M4 or 8-32	Thru hole	N7-22-10	N7-72-10	13 (.51)	4.5 (.180)	~	17.7 (.70)	12.5 (.49)	8.7 (.34)	7.9 (.31)	8 ⁺⁰ _{-0.08} (.315 ⁺⁰ _{-0.003})
	Blind hole	N7-22-11	N7-72-11		5.4 (.21)	13.2 (.52)	23 (.91)	17.9 (.70)			
M5 or 10-32	Thru hole	N7-32-10	N7-82-10	13 (.51)	4.5 (.180)	~	17.7 (.70)	12.5 (.49)	9 (.35)	7.9 (.31)	8 ⁺⁰ _{-0.08} (.315 ⁺⁰ _{-0.003})
	Blind hole	N7-32-11	N7-82-11		5.4 (.21)	13.2 (.52)	23 (.91)	17.9 (.70)			
M6 or 1/4-20	Thru hole	N7-42-10	N7-92-10	14.6 (.58)	6.4 (.25)	~	22.8 (.90)	16 (.63)	10 (.39)	9.4 (.37)	9.5 ^{+0.1} ₋₀ (+.004) (-0)
	Blind hole	N7-42-11	N7-92-11		7 (.28)	16.4 (.65)	29.5 (1.16)	23 (.91)			

Installation Guidelines

for *SOUTHCO*[®] Self-Clinching products

Self-clinching product installation is offered on these *SOUTHCO*[®] products, making them easy-to-use captive panel fasteners:

- Captive Screws
- Receptacles for Quarter-turn Fasteners
- Receptacles for Fast-lead Thread Screws

When pressed into a properly prepared hole, self-clinching captive fasteners cold-flow (move) the panel material into the retaining groove of the fastener. This material then retains the fastener in the panel.

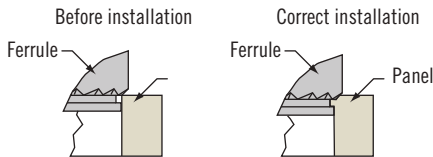

Successful press-in installations depend on:

Material:

The hardness of the panel material must not exceed *SOUTHCO*[®] recommendations. If the panel is too hard, the fastener will not install correctly.

Installation Holes:

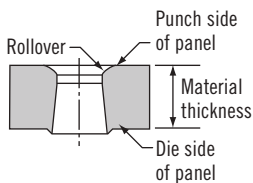
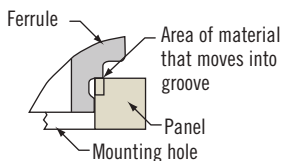

Mounting holes may be drilled, punched, or cast.

- Hole edge: the top hole edge must be sharp but with no broken edges.

Do not chamfer or debur edge.

- Punched holes: use a punch and die with a small clearance to minimize the rollover and fracture angle.
- Hole diameter: measure the hole diameter at the panel surface on the side on which the fastener will be installed. The diameter must be within *SOUTHCO*[®] specifications for that product.

- If the hole is too large, not enough material will flow into the retaining groove and the fastener may not be retained adequately.

- If the hole is too small, the fastener will not fit and installation may become difficult and unsafe.

- Hole distance from the edge of panel: the minimum recommended

- Spring-loaded Plungers
- Captive Nuts
- Threaded Inserts

distance is 1.5 x the diameter of the mounting hole, unless otherwise indicated.

- Installing too close to the edge will cause the material to flow in the opposite direction, deforming the edge of the panel. To install closer to the edge, you may need to restrain the panel edge.

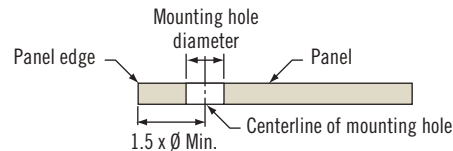

Panel Thickness:

The thickness of the panel at the mounting hole location must meet or exceed Southco's stated minimum recommendations.

If the material is too thin, panel deformation and/or damage to the fastener may result.

Installation is fast and easy if you follow these tips:

How to install: Use the recommended force where noted and a proper back-up tool.

- use any parallel-acting press
- use a punch whose diameter is larger than the head of the fastener

Installation Force: Proper installation requires an even distribution of adequate force. It does not depend on the distance the fastener is pressed into the panel.

- Southco does not recommend using a hammer. The impact force does not provide an even distribution of force to allow the panel material to completely flow into the fastener's retaining groove.
- Installation force varies from application to application, depending on the criteria noted above.

- On parts without a collar to provide a hard stop, press-in until the edge of the knurl is just barely visible.

When to Install:

Installation is recommended after plating or finishing has been applied to the panel.

The hole diameter must meet specifications before finish or plating is applied.

- Do not over-install parts. This interrupts the material and will reduce the retention strength.

